

CWTF 2/2 TWIN (2U/2L Warmers)

19.1" x 17.7" x 16.4"
(48.5cm x 45.0cm x 41.7cm)

- Medium volume, twin brew head system
- All stainless steel construction
- Hot water faucet and pourover feature
- Four individually controlled warming stations
- SplashGard® funnel deflects hot liquids away from the hand



 Servers and airpots sold separately

Agency:



Specifications

Product #: 23400.0001

Warmers: Two Upper/ Two Lower

Water Access: Plumbed

Finish: Stainless

Funnel: Stainless Steel

Faucet: Upper

Additional Features

Pourover Option

Electrical & Capacity

Volts	Amps	Watts	Cord Attached	Plug Type	8oz cups/hr 236ml cups/hr	Input H ² O Temp.	Phase	# Wires plus Ground	Hertz
120/240	27.7	6650	No	-	240	60°F (15.5°C)	1	3	60

Plumbing Requirements

PSI	kPa	Fitting Supplied	Water Flow Required (GPM)
20-90	138-621	3/8" Male Flare Fitting	-

CAD Drawings

2D	Revit	KLC
●		



BUNN® reserves the right to change specifications and product design without notice. Such revisions do not entitle the buyer to corresponding changes, improvements, additions or replacements for previously purchased equipment. For most current specifications and other info visit bunn.com.

Created on:
05/10/2017

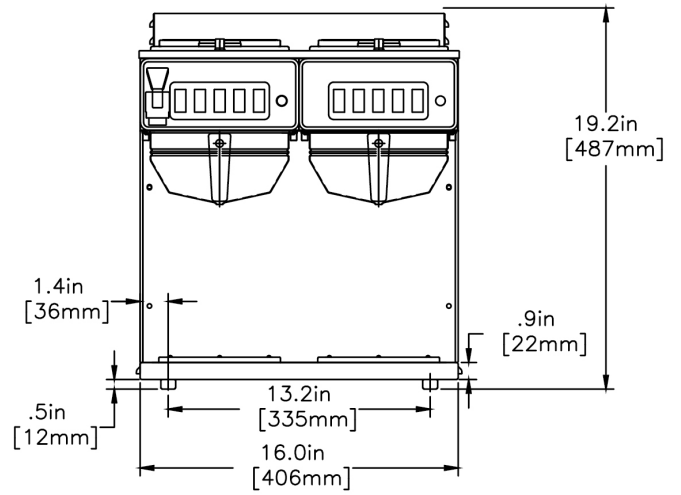
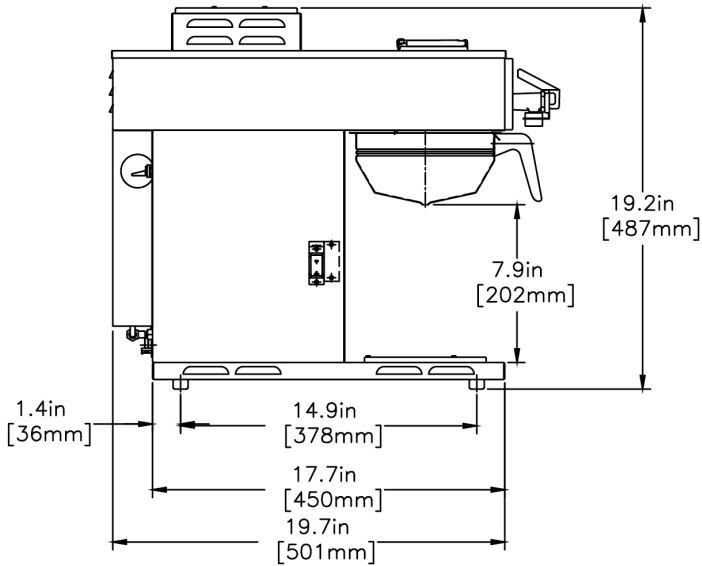
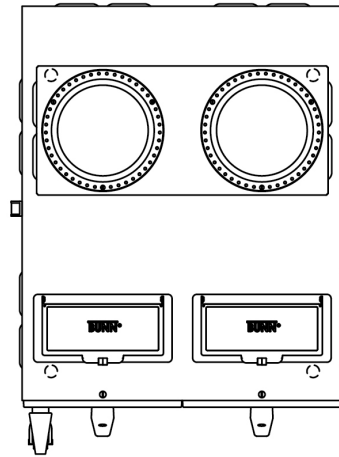
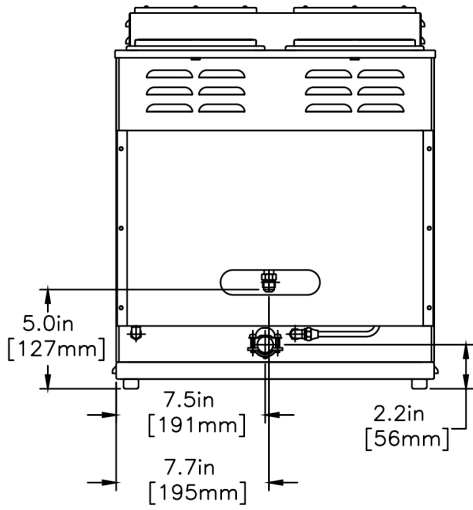

	Unit			Shipping				
	Width	Height	Depth	Width	Height	Depth	Weight	Volume
English	16.4 in.	19.1 in.	17.7 in.	-	-	-	56.000 lbs	5.939 ft ³
Metric	41.7 cm	48.5 cm	45.0 cm	-	-	-	25.402 kgs	0.168 m ³



BUNN® reserves the right to change specifications and product design without notice. Such revisions do not entitle the buyer to corresponding changes, improvements, additions or replacements for previously purchased equipment. For most current specifications and other info visit bunn.com.

Created on:
05/10/2017

Related Products & Accessories: CWTF 2/2 TWIN (2U/2L Warmers)(23400.0001)



FILTERS,REGULAR1M
500/2 50/CL

Product #: 20115.0000



FUNNEL ASSY,SST-BLK
HDL(7.62

Product #: 20217.0000



WATER FILTER
SYSTEM,EQ-17-TL

Product #: 30200.1000



WATER FILTER,IN LINE
ED-17-TL

Product #: 30201.1001



BUNN® reserves the right to change specifications and product design without notice. Such revisions do not entitle the buyer to corresponding changes, improvements, additions or replacements for previously purchased equipment. For most current specifications and other info visit bunn.com.

Created on:
05/10/2017

Serving & Holding Options: CWTF 2/2 TWIN (2U/2L Warmers)(23400.0001)



EASY POUR,(BLK) 1/CS

Product #:06100.0101



EASY POUR,(BLK) 2/CS

Product #:06100.0102



EASY POUR,(BLK) 3/CS

Product #:06100.0103



EASY POUR,(BLK) 6/CS

Product #:06100.0106



EASY POUR,(BLK) 12/CS

Product #:06100.0112



EASY POUR,(BLK) 24/CS

Product #:06100.0124



EASY POUR,(BLK) 6-1/2 CS

Product #:06100.0156



EASY POUR,(ORN) 1/CS

Product #:06101.0101



EASY POUR,(ORN) 2/CS

Product #:06101.0102



EASY POUR,(ORN) 3/CS

Product #:06101.0103



EASY POUR,(ORN) 6/CS

Product #:06101.0106



EASY POUR,(ORN) 12/CS

Product #:06101.0112



EASY POUR,(ORN) 24/CS

Product #:06101.0124



DECANTER, GLASS-BLK 12C 24/CS

Product #:42400.0024



DECANTER, GLASS-BLK 12CUP 1PK

Product #:42400.0101



DECANTER, GLASS-BLK 12C 3/CS

Product #:42400.0103



DECANTER, GLASS-ORN 12C 24/CS

Product #:42401.0024



DECANTER, GLASS-ORN 12 CUP 1PK

Product #:42401.0101



DECANTER, GLASS-ORN 12C 3/CS

Product #:42401.0103



BUNN® reserves the right to change specifications and product design without notice. Such revisions do not entitle the buyer to corresponding changes, improvements, additions or replacements for previously purchased equipment. For most current specifications and other info visit bunn.com.

Created on:
05/10/2017