

BUNN®

SRUA

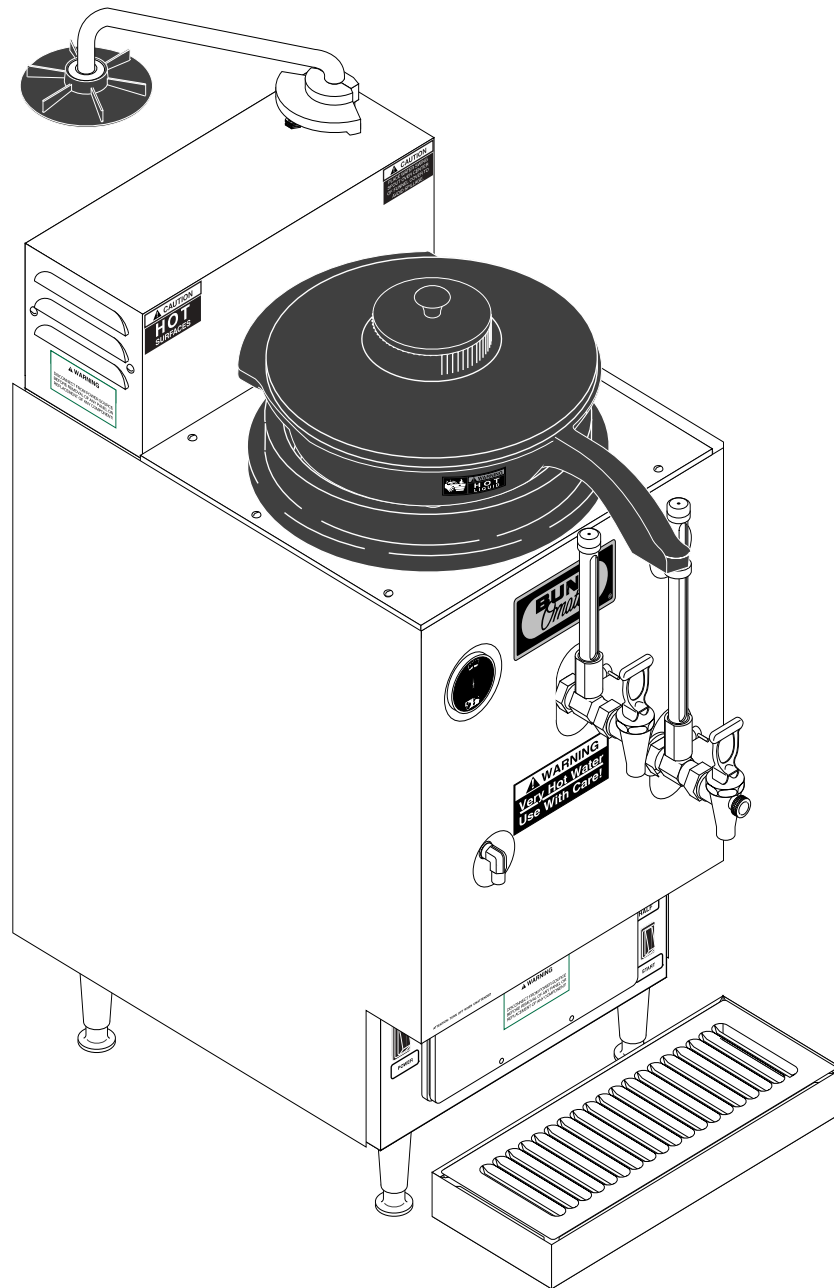

OPERATING & SERVICE MANUAL

BUNN-O-MATIC CORPORATION

POST OFFICE BOX 3227

SPRINGFIELD, ILLINOIS 62708-3227

PHONE: (217) 529-6601 FAX: (217) 529-6644

INTRODUCTION

This brewer will brew a three gallon batch of coffee into the reservoir, which has its own dispensing faucet. The brewer also has a hot water faucet for allied beverage use. It is only for indoor use on a sturdy counter.

BUNN-O-MATIC COMMERCIAL PRODUCT WARRANTY

Bunn-O-Matic Corp. ("BUNN") warrants equipment manufactured by it as follows:

- 1) All equipment other than as specified below: 2 years parts and 1 year labor.
- 2) Electronic circuit and/or control boards: parts and labor for 3 years.
- 3) Compressors on refrigeration equipment: 5 years parts and 1 year labor.
- 4) Grinding burrs on coffee grinding equipment to grind coffee to meet original factory screen sieve analysis: parts and labor for 3 years or 30,000 pounds of coffee, whichever comes first.

These warranty periods run from the date of installation BUNN warrants that the equipment manufactured by it will be commercially free of defects in material and workmanship existing at the time of manufacture and appearing within the applicable warranty period. This warranty does not apply to any equipment, component or part that was not manufactured by BUNN or that, in BUNN's judgment, has been affected by misuse, neglect, alteration, improper installation or operation, improper maintenance or repair, damage or casualty. This warranty is conditioned on the Buyer 1) giving BUNN prompt notice of any claim to be made under this warranty by telephone at (217) 529-6601 or by writing to Post Office Box 3227, Springfield, Illinois 62708-3227; 2) if requested by BUNN, shipping the defective equipment prepaid to an authorized BUNN service location; and 3) receiving prior authorization from BUNN that the defective equipment is under warranty.

THE FOREGOING WARRANTY IS EXCLUSIVE AND IS IN LIEU OF ANY OTHER WARRANTY, WRITTEN OR ORAL, EXPRESS OR IMPLIED, INCLUDING, BUT NOT LIMITED TO, ANY IMPLIED WARRANTY OF EITHER MERCHANTABILITY OR FITNESS FOR A PARTICULAR PURPOSE. The agents, dealers or employees of BUNN are not authorized to make modifications to this warranty or to make additional warranties that are binding on BUNN. Accordingly, statements by such individuals, whether oral or written, do not constitute warranties and should not be relied upon.

If BUNN determines in its sole discretion that the equipment does not conform to the warranty, BUNN, at its exclusive option while the equipment is under warranty, shall either 1) provide at no charge replacement parts and/or labor (during the applicable parts and labor warranty periods specified above) to repair the defective components, provided that this repair is done by a BUNN Authorized Service Representative; or 2) shall replace the equipment or refund the purchase price for the equipment.

THE BUYER'S REMEDY AGAINST BUNN FOR THE BREACH OF ANY OBLIGATION ARISING OUT OF THE SALE OF THIS EQUIPMENT, WHETHER DERIVED FROM WARRANTY OR OTHERWISE, SHALL BE LIMITED, AT BUNN'S SOLE OPTION AS SPECIFIED HEREIN, TO REPAIR, REPLACEMENT OR REFUND.

In no event shall BUNN be liable for any other damage or loss, including, but not limited to, lost profits, lost sales, loss of use of equipment, claims of Buyer's customers, cost of capital, cost of down time, cost of substitute equipment, facilities or services, or any other special, incidental or consequential damages.

USER NOTICES

Carefully read and follow all notices on the brewer and in this manual. They were written for your protection. All notices on the brewer are to be kept in good condition. Replace any unreadable or damaged labels.

⚠ WARNING
<ul style="list-style-type: none">◆ Fill water tank before turning -on thermostat or connecting appliance to power source.◆ Use only on a properly protected circuit capable of the rated load.◆ Electrically ground the chassis.◆ Follow national/local electrical codes.◆ Do not use near combustibles.
FAILURE TO COMPLY RISKS EQUIPMENT DAMAGE, FIRE, OR SHOCK HAZARD
READ THE ENTIRE OPERATING MANUAL BEFORE BUYING OR USING THIS PRODUCT
THIS APPLIANCE IS HEATED WHENEVER CONNECTED TO A POWER SOURCE
<small>00831.0000F 3/98 © 1988 BUNN-O-MATIC CORPORATION</small>

#00831.0000

ATTENTION: TURN OFF WHEN UNATTENDED

#00878.0000

⚠ WARNING
<u>Very Hot Water</u>
Use With Care!

#12593.0000

⚠ CAUTION
HOT SURFACES

#12555.0000

This equipment is to be installed to comply with the Basic Plumbing Code of the Building Officials and Code Administrators International, Inc. (BOCA) and the Food Service Sanitation Manual of the Food and Drug Administration (FDA).

#00656.0000

⚠ WARNING
Disconnect from power source before removal of any panel or replacement of any component!

#10044.0000

	⚠ WARNING
	REMOVE FUNNEL SLOWLY

#03408.0000

	⚠ WARNING
	HOT LIQUID

#03409.0000

⚠ CAUTION
PLACE WATER SWING SPOUT OVER CENTER OF FUNNEL COVER TO AVOID SPILLAGE.

#29299.0000

ELECTRICAL REQUIREMENTS

CAUTION - The brewer must be disconnected from the power source until specified in *Initial Set-Up*.

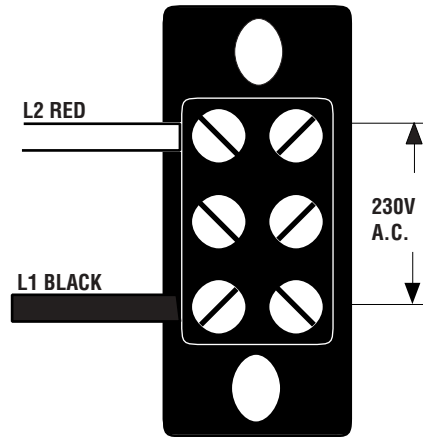

P1842

SRUA Models require 2-wire, grounded service rated 230 volts ac, 30 amp, single phase, 50 Hz. Proceed as follows:

ELECTRICAL INSTALLATION INSTRUCTIONS

CAUTION – Improper electrical installation can damage the equipment and injure the installer. The chassis must be properly grounded. Do not assume a plumbing line will provide an adequate ground.

1. An electrician must provide electrical service as specified.
2. Using a voltmeter, check the voltage and color coding of each conductor at the electrical source.
3. Before electrically connecting the brewer, remove the left side panel from the hood and rotate the control thermostat knob fully clockwise to the "OFF" position. Keep this knob in the "OFF" position until performing the *Initial Setup*. Replace the side panel.
4. Remove the lower front panel and connect the proper electrical service to the terminal block.
5. Connect the brewer to the power source and verify the voltage at the terminal block before proceeding. Replace the lower front panel.
6. Disconnect the brewer from the power source. If plumbing has been hooked up, the brewer is ready for the *Initial Setup*.

NOTE: A Schematic wiring diagram is included in this manual.

PLUMBING REQUIREMENTS

The brewer must be connected to a cold water system with operating pressure between 20 and 90 psi (138 and 621 kPa) from a 1/2" or larger supply line. A shut-off valve should be installed in the line before the brewer. Install a regulator in the line when pressure is greater than 90 psi (621 kPa) to reduce it to 50 psi (345 kPa). The water inlet fitting is 3/8" flare.

NOTE - Bunn-O-Matic recommends 3/8" copper tubing for installations from the 1/2" water supply line. Bunn-O-Matic does not recommend the use of a saddle valve to install the brewer. The size and shape of the hole made in the supply line by this type of device may restrict water flow.

PLUMBING REQUIREMENTS(cont.)

Plumbing Hook-up

1. Make certain the 3/8" female flare fittings on the short tube from the outlet of strainer (supplied) is securely attached to the male fitting at the bottom rear of the brewer.
2. Flush the water line and securely attach it to the 3/8" male flare fitting on the inlet of the strainer.
3. Turn on the water supply.
4. Inspect the connection for leaks.

This equipment must be installed to comply with the Basic Plumbing Code of the Building Officials and Code Administrators International, Inc. (BOCA) and the Food Service Sanitation Manual of the Food and Drug Administration (FDA).

INITIAL SETUP

CAUTION - The brewer must be disconnected from the power source throughout the *Initial Setup*, except when specified in the instructions.

IMPORTANT: Brewer must be level and installed on a sturdy structure.

Electrician's and Plumber's Instructions are provided. These instructions should be carefully followed before proceeding with *Initial Setup*.

Be sure all electrical and plumbing connections are tight.

1. Disconnect the brewer from the power source.
2. Remove the left side panel from the hood and rotate the control thermostat knob fully counterclockwise to the "OFF" position. Replace the side panel.
3. Connect the brewer to the power source and place the lighted ON/OFF switch in the "ON" position. Water will flow into the tank and should automatically stop after approximately 15 minutes.

NOTE - The lighted ON/OFF switch must be in the "ON" position to automatically refill the tank. The switch should be in the "OFF" position whenever the brewer is left unattended.

4. Disconnect the brewer from the power source.
5. Remove the left side panel from the hood and rotate the control thermostat knob clockwise to the 5 o'clock position. Replace the side panel.
6. Connect the brewer to the power source and wait for the water in the tank to heat to the proper temperature. This will take approximately 1-2 hours, depending on the incoming water temperature. Some water will flow from the overflow tube during this time due to expansion. Draw off a 1/2 gallon decanter of water every 15 minutes during the initial heat-up to lessen the chance of hot water flow from this expansion.
7. Determine the water temperature by checking the water with a thermometer at the hot water faucet (red handle). The best brewing temperature is between 195°(91°C) and 200°F(93°C). The temperature may be increased by turning the thermostat knob clockwise and decreased by turning the knob counterclockwise.
8. When the desired temperature is attained, place the funnel support, funnel, and funnel cover on top of the coffee reservoir. Center the discharge of the water swing spout over the opening in the top of the funnel cover.
9. Place the lighted ON/OFF switch in the "ON" position and momentarily press and release the start switch. Water should flow from the swing spout into the funnel assembly.
10. Drain and measure the water from the reservoir when the flow of water from this initial cycle stops. If it is three gallons, proceed to step 12. If it is more or less than three gallons, proceed to step 11.
11. Adjust the brew timer as required. See *Adjusting Brew Volumes*. Repeat steps 9 & 10.
12. The brewer is now properly adjusted to brew coffee.

ADJUSTING BREW VOLUMES

CAUTION - Disconnect the power source from the brewer prior to the removal of any panel for the replacement or adjustment of any component.

NOTE: Prior to setting or modifying batch sizes, check that the brewer is connected to water supply, the tank is properly filled, and a funnel support, funnel and funnel cover are in place.

1. **Modifying batch sizes.** To modify a batch volume, first check that the SET/LOCK switch is in the “SET” position on the circuit board.

To increase a batch size. Press and hold the START or BREW switch until you see three breaks in the water stream from the swing arm. Release the switch (Failure to release the switch within two seconds after the third break in the water stream causes the volume setting to be aborted and previous volume setting will remain in memory) and press it again one or more times. Each time the switch is pressed, two seconds are added to the brew time period. Allow the brew cycle to finish in order to verify that the desired volume has been achieved.

To decrease a batch size. Press and release the START or BREW switch once for every two-second interval to be removed from the total brew time period; then immediately press and hold down the START or BREW switch until you see three breaks in the water stream from the swing arm. Release the switch. (Failure to release the switch within two seconds after the third break in the water stream causes the volume setting to be aborted and previous volume setting will remain in memory). Allow the brew cycle to finish in order to verify that the desired volume has been achieved.

2. **Setting batch sizes.** To set a batch volume, first check that the SET/LOCK switch is in the “SET” position on the circuit board. Press and hold the START or BREW switch until you see three breaks in the water stream from the swing arm, and then release the switch. (Failure to release the switch within two seconds after the third break in the water stream causes the volume setting to be aborted and previous volume setting will remain in memory). View the level of the liquid being dispensed. When the desired level is reached, turn the ON/OFF switch to “OFF” (lower). The brewer remembers this volume and will continue to brew batches of this size until the volume setting procedure is repeated.

NOTE: When brewing coffee, batch volumes will decrease due to absorption by the coffee grounds.

NOTE: HALF-BATCH AND FULL BATCH SETTINGS MUST EACH BE SET SEPARATELY

3. **Setting programming disable feature.** If it becomes necessary to prevent anyone from changing brew times once programmed, you can set the SET/LOCK switch to the “LOCK” position. This will prevent any programming until switch is once again placed in the “SET” position.

COFFEE BREWING

1. Brew cycles may be started whenever water temperature is correct. This condition is indicated by the dial thermometer on front of the brewer. Whenever the pointer is in the green, brewer is ready for brewing.
2. Insert a Bunn® filter in funnel and add desired amount of coffee.
3. Level the bed of coffee and place funnel into the funnel support. Place funnel cover over the funnel and be sure the water swing spout is over the center of the funnel cover.
4. Turn "ON/OFF" switch to the "ON" position.(This switch must be in the "ON" position to start and complete a brewing cycle.)
5. Push and release "START" switch to start the brew cycle.
6. Water swing spout should not be moved as long as water is flowing into the funnel cover. When water stops flowing, it may then be moved for access to brewing funnel.
7. Remove funnel cover. Funnel should not be removed from urn until drip out of coffee has been completed.
8. To empty funnel, invert it over a waste container to dispose of filter and grounds. An additional flange is provided on the funnel to help make this step easier.

NOTE: Hot water may be drawn from the hot water faucet during a brew cycle. However, if a large amount of hot water is drawn off (over 1 gallon) operator should wait to do so between brewing cycles.

CLEANING

NOTE: Tank and tank components should be delimed regularly based on local water conditions. Excessive mineral build up on stainless steel surfaces can initiate corrosion reactions resulting in serious leaks,

1. Remove funnel, funnel lid and support. Under hot water, rinse away all coffee oils. Wipe with a clean damp cloth.
2. Drain coffee reservoir by opening coffee faucet. When empty, close faucet.
3. Cycle two or three inches of water into the coffee reservoir, adding a bucket of crushed ice to obtain a more desirable cleaning temperature, and scrub entire reservoir area.
4. Drain coffee reservoir and rinse. Use clean damp cloth to wipe reservoir.
5. Install coffee funnel support, funnel and funnel lid.
6. Remove the sight gauge cap, insert sight gauge cleaning brush into the sight gauge glass tube and clean.
7. To clean coffee faucet, remove the faucet handle from the faucet and faucet clean out cap. Clean faucet with a faucet cleaning brush and wipe all parts with a damp cloth. Replace faucet seat cup periodically if badly stained or to stop faucet dripping. **DO NOT CLEAN THE HOT WATER FAUCET.**
8. Reassemble the coffee faucet.
9. Wipe the entire outside surface of the machine with a clean damp cloth. Wipe dry.

CAUTION - Surfaces of machine are hot.

FILTER HOLDER

1. A filter holder is supplied with each SRU coffee brewer. Its purpose is to keep the filters in their originally formed shape to properly fit the brewer funnel.
2. It is suggested that only one cluster of filters be placed in the holder at one time for best results.
3. Not using the filter holder may permit the filters to gradually widen out towards a flat shape, especially so if humidity is present. Once a filter has lost its upright side walls, it may tend to collapse inward when placed in the brewing funnel. If this happens the hot water spray may cause one side to fall inwards, letting coffee grounds flow over the edge of filter and into the brewed coffee. Proper use of the holder should prevent this problem.

TROUBLESHOOTING

A troubleshooting guide is provided to suggest probable causes and remedies for the most likely problems encountered. If the problem remains after exhausting the troubleshooting steps, contact the Bunn-O-Matic Technical Service Department.

- Inspection, testing, and repair of electrical equipment should be performed only by qualified service personnel.
- All electronic components have 230 volt ac and low voltage dc potential on their terminals. Shorting of terminals or the application of external voltages may result in board failure.
- Intermittent operation of electronic circuit boards is unlikely. Board failure will normally be permanent. If an intermittent condition is encountered, the cause will likely be a switch contact or a loose connection at a terminal or crimp.
- Solenoid removal requires interrupting the water supply to the valve. Damage may result if solenoids are energized for more than ten minutes without a supply of water.
- The use of two wrenches is recommended whenever plumbing fittings are tightened or loosened. This will help to avoid twists and kinks in the tubing.
- Make certain that all plumbing connections are sealed and electrical connections tight and isolated.
- This brewer is heated at all times. Keep away from combustibles.

- WARNING** –
- Exercise extreme caution when servicing electrical equipment.
 - Unplug the brewer when servicing, except when electrical tests are specified.
 - Follow recommended service procedures
 - Replace all protective shields or safety notices

PROBLEM	PROBABLE CAUSE	REMEDY
Brew cycle will not start	1. No water	Water lines and valves to the brewer must be open.
	2. No power or incorrect voltage to the brewer	(A) Check the terminal block for 230 volts ac across the red and black terminals. (B) Check fuse.
	3. Water level below pump housing. (Water level in the hot water gauge glass should be approximately half full).	Be sure water shut-off valve is open and that the in-line filters or strainers are not blocking water flow.
	4. Swing Arm Switch	Refer to <i>Service</i> - Swing Arm Switch for testing procedures. See page 25
	5. ON/OFF Switch	Refer to <i>Service</i> - ON/OFF Switch for testing. See page 20

TROUBLESHOOTING (cont.)

PROBLEM

PROBABLE CAUSE

REMEDY

Brew cycle will not start (cont.)

6. Start Switch

Refer to *Service* - Start Switch for testing procedures. See page 24

7. Timer

Refer to *Service* - Timer for testing procedures. See page 28 or 29

8. Pump

Refer to *Service* - Pump for testing procedures. See page 21

9. Solenoid Valve

Refer to *Service* - Solenoid Valve for testing procedures. See page 23

10. Strainer

(A) Direction of flow arrow must be pointing towards brewer.

(B) Remove the strainer and check for obstructions. Clear or replace.

Tank not filling

1. ON/OFF Switch (This switch must be in the "ON" position for the refill circuit to operate.)

Refer to *Service* - ON/OFF Switch for testing procedures. See page 20

2. No water

Be sure water shut-off is open and that in-line filters or strainers are not blocking water flow.

3. Solenoid Valve

Refer to *Service* - Solenoid Valve for testing procedures. See page 23

4. Probe

Refer to *Service* - Probe for testing procedures. See page 18

5. Liquid Level Board

Refer to *Service* - Liquid Level Board for testing procedures. See page 18

TROUBLESHOOTING (cont.)

PROBLEM	PROBABLE CAUSE	REMEDY
Water running out of the overflow	1. Brewer not level	Brewer must be level and installed on a sturdy structure.
	2. Solenoid Valve	Refer to <i>Service</i> - Solenoid Valve for testing procedures. See page 23
	3. Liquid Level Board	Refer to <i>Service</i> -Liquid Level Board for testing procedures. See page 18
	4. Probe	Refer to <i>Service</i> - Probe for testing procedures. See page 18
Water is not hot	1. Limit Thermostat CAUTION - Do not eliminate or bypass limit thermostat. Use only Bunn-O-Matic replacement part #29329.1000.	Refer to <i>Service</i> - Limit Thermostat for testing procedures. See page 17
	2. Control Thermostat	Refer to <i>Service</i> - Control Thermostat for testing procedures. See page 15
	3. Tank Heater	Refer to <i>Service</i> - Tank Heater for testing procedures. See page 26
	4. Contactor	Refer to <i>Service</i> - Contactor for testing procedures. See page 14
	5. Thermal fuses	Refer to <i>Service</i> - thermal fuses for testing procedures. See page 27
Fuse Opening	1. Fuse	Refer to <i>Service</i> - Fuse for testing procedures. See page 16
	2. Tank Heater	Refer to <i>Service</i> - Tank Heater for testing procedures. See page 26

TROUBLESHOOTING (cont.)

PROBLEM	PROBABLE CAUSE	REMEDY
Water keeps running from swing spout	1. Timer	Refer to <i>Service</i> - Timer for testing procedures. See page 28 or 29
	2. Start Switch	Refer to <i>Service</i> - Start Switch for testing procedures. See page 24
Inconsistent coffee yield	1. Timer	Refer to <i>Service</i> - Timer for testing procedures. See page 28 or 29
	2. Solenoid Valve	Refer to <i>Service</i> - Solenoid Valve for testing procedures. See page 23
	3. Lime build-up in swing spout and pump tubing.	Remove swing spout and insert delimiting rod down into pump tubing as far as possible.
Funnel overflows	1. Filters	Use Bunn filters made for the SRU brewer.
	2. Hole in bottom of funnel obstructed.	Remove obstruction.
	3. Pump - Flow Rate	Check pump flow rate with a watch. Pump flow rate should be approximately 24 ounces in 15 seconds. Be sure pump assembly is free of any obstructions.
	4. Soft Water	When using a water softener, a coarse grind of coffee may be preferred. If required, a bypass system is available as an optional feature.

TROUBLESHOOTING (cont.)

PROBLEM

Coffee reservoir overflows

PROBABLE CAUSE

1. Coffee reservoir not completely empty before a brew cycle was started.
2. Timer
3. Pump - Flow Rate

REMEDY

Be sure coffee reservoir is empty before brew cycle is started.

Refer to *Service* -Timer for testing procedures. See page 28 or 29

Check pump flow rate with a watch. Pump flow rate should be approximately 24 ounces in 15 seconds. Be sure pump assembly is free of any obstructions.

Brewer is making unusual noises

1. Plumbing lines
2. Water supply

Plumbing lines should not be resting on the counter top.

(A) The brewer must be connected to a cold water line.

(B) Water pressure to the brewer must not exceed 90 psi (621 kPa). Install a regulator if necessary to lower the pressure to approximately 50 psi (345 kPa).

3. Tank Heater

Remove and clean lime off the tank heater. See page 26

SERVICE

This section provides procedures for testing and replacing various major components used in this brewer should service become necessary. Refer to *Troubleshooting* for assistance in determining the cause of any problem.

WARNING - Inspection, testing, and repair of electrical equipment should be performed only by qualified service personnel. The brewer should be unplugged when servicing, except when electrical tests are required and the test procedure specifically states to plug in the brewer.

COMPONENT ACCESS

WARNING - Disconnect the brewer from the power source before the removal of any panel or the replacement of any component.

The control thermostat, limit thermostat, pump, solenoid valve, liquid level probe, swing spout switch and tank heater are accessible by removal of the swing spout, side cupola covers and the cupola.

Disconnect the swing spout nut from the swing spout base fitting. Remove swing spout.

Remove the four #8-32 screws, two on each side, securing the side covers to the cupola.

Slip cupola off of the component bracket.

The on/off switch, selector switch, start switch, timer, contactor and liquid level control board are accessible by removal of the front access panel.

Remove the four #8-32 screws securing the front access panel to the base.

The fuse and fuse holder are accessible by removal of the rear utility cover.

Remove the six #8-32 screws securing the rear utility cover to the housing.

Contents

Contactor	14
Control Thermostat	15
Fuse and Fuse Holder	16
Limit Thermostat	17
Liquid Level Board and Level Probe	18
ON/OFF Switch	20
Pump	21
Selector Switch (Half Batch)	22
Solenoid	23
Start Switch (Brew)	24
Swing Arm Switch	25
Tank Heater	26
Thermal Fuse	27
Timer	28
Digital Timer	29
Wiring Diagram	31

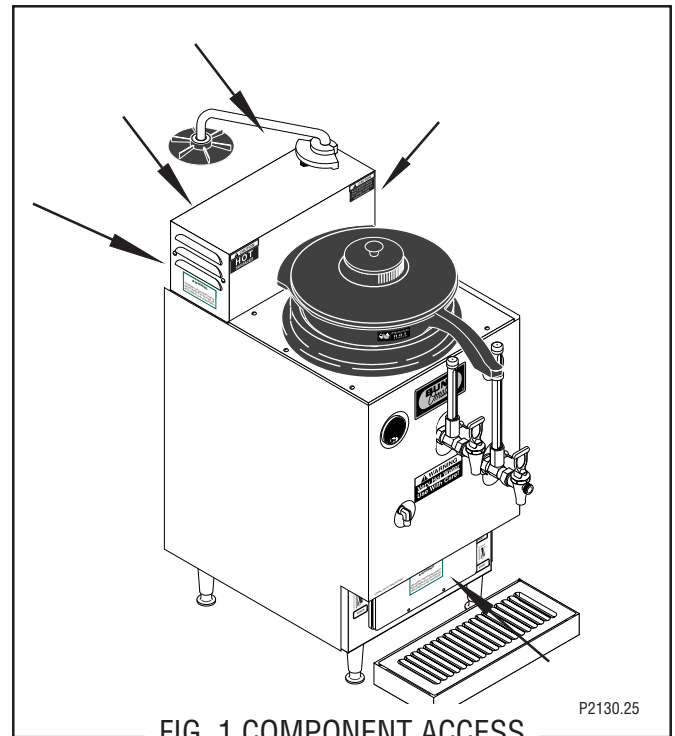

SERVICE (cont.) CONTACTOR

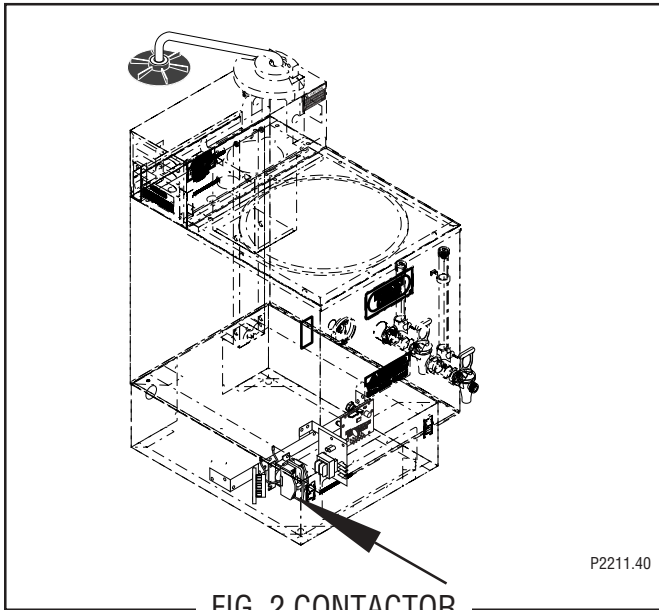

Location:

The contactor is located inside the front lower access panel, left of center on the component bracket.

Test Procedures:

1. Disconnect the brewer from the power source.
2. Disconnect the red wire from contactor coil to the control thermostat and the black wire from the contactor coil to the main harness.
3. Connect the brewer to the power source.
4. Check the voltage across the control thermostat wire and the wire from the the main harness. The indication must be 230 volts ac.
5. Disconnect the brewer from the power source. If voltage is present as described, proceed to #6. If voltage is not present as described refer to the Wiring Diagram and check the brewer wiring harness.
6. Check for continuity between the left and right terminals on the contactor coil. If continuity is present as described, reconnect the wires and proceed to #7. If continuity is not present as described, replace the contactor.
7. On all brewers check the voltage across the upper left terminal and the upper right terminal on the contactor with a voltmeter. Connect the brewer to the power source. The indication must be 230 volts ac.
8. Disconnect the brewer from the power source.

If voltage is present as described, proceed to #9. If voltage is not present as described, refer to the wiring diagram and check the brewer wiring harness.

9. Check for continuity across the terminals on the left side of the contactor by manually closing the contacts. Continuity must not be present when the contact is released.
10. Check for continuity across the terminals on the right side of the contactor by manually closing the contacts. Continuity must not be present when the contact is released.

If continuity is present as described, the contactor is operating properly.

If continuity is not present as described, replace the contactor.

Removal and Replacement:

1. Disconnect all the wires from the contactor.
2. Remove the two #8-32 screws securing the contactor to the contactor mounting bracket.
3. Install new contactor and secure with two #8-32 screws.
4. Refer to Fig. 3 and reconnect the wires.

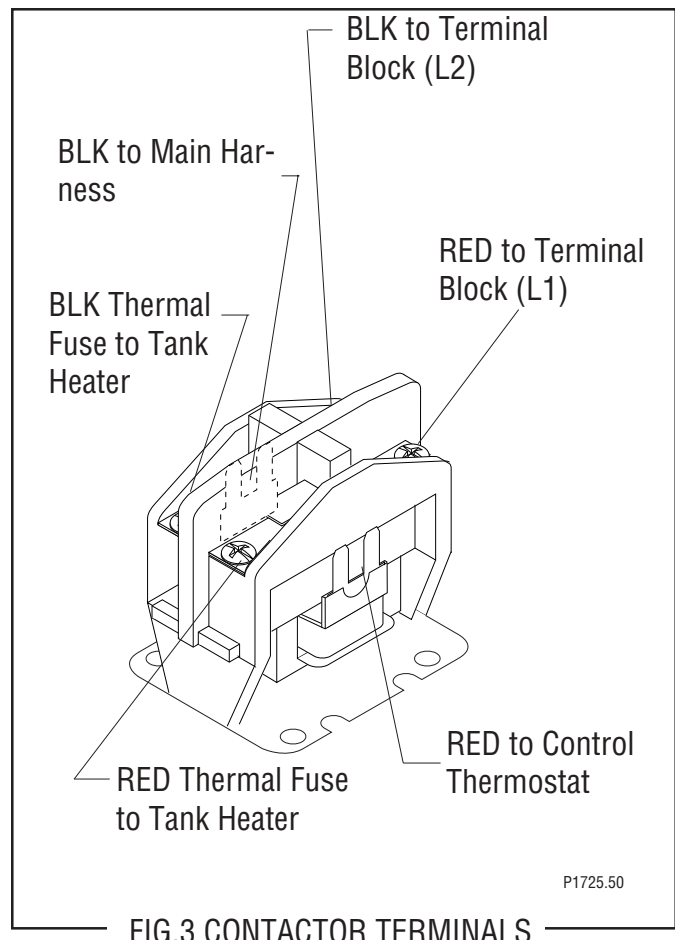

SERVICE (cont.)
CONTROL THERMOSTAT

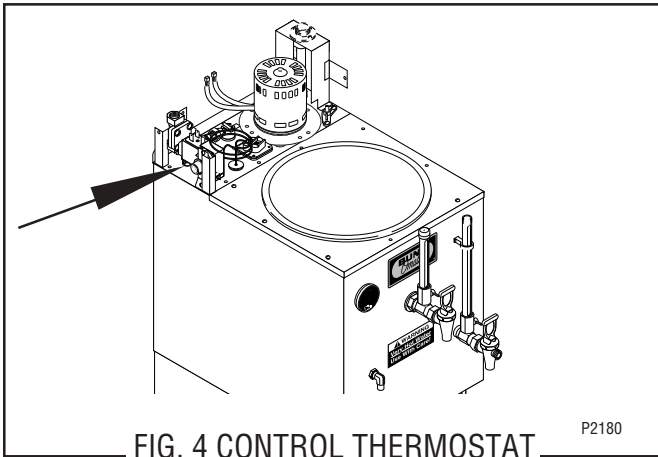

Location:

The control thermostat is mounted on the left front of the top component bracket.

Test Procedures:

1. Disconnect the brewer from the power source.
2. Locate the thermostat and check for 230 volts ac between the red wire from the limit thermostat to the control thermostat and the black wire on the main terminal block.
3. Disconnect the brewer from the power source.

If voltage is present as described, proceed to #4.
 If voltage is not present as described, refer to the wiring diagram and check the brewer wiring harness.

4. Disconnect the red wires from the control thermostat.
5. Check for continuity across the terminals on the control thermostat with the control thermostat in the "ON" position (fully clockwise), continuity must not be present when the thermostat is in the "OFF" position (fully counterclockwise).

If continuity is present as described, the control thermostat is operating properly.
 If continuity is not present as described, replace the control thermostat.

Removal and Replacement:

1. Disconnect the wires from the control thermostat.
2. Remove the thermostat capillary bulb by firmly pulling up on the capillary at the component bracket. This will disengage the grommet from the component bracket.
3. Remove the #8-32 screw securing the control thermostat and mounting bracket to the component bracket. Remove control thermostat and bracket as an assembly.
4. Remove knob from control thermostat.
5. Remove the two #6-32 screws securing the control thermostat to the thermostat mounting bracket. Remove and discard thermostat.
6. Install new control thermostat on thermostat mounting bracket and secure with two #6-32 screws.
7. Install knob on thermostat.
8. Install thermostat and mounting bracket on the component bracket and secure with one #8-32 screw.
9. Carefully bend the capillary tube so that the tube and bulb inside the brewer are in the vertical position with the grommet located 5 1/2" above the capillary bulb.

NOTE: The capillary tube must be clear of any electrical termination and not kinked.

10. Refer to Fig. 5 and reconnect the wires.
11. Adjust the control thermostat as required.

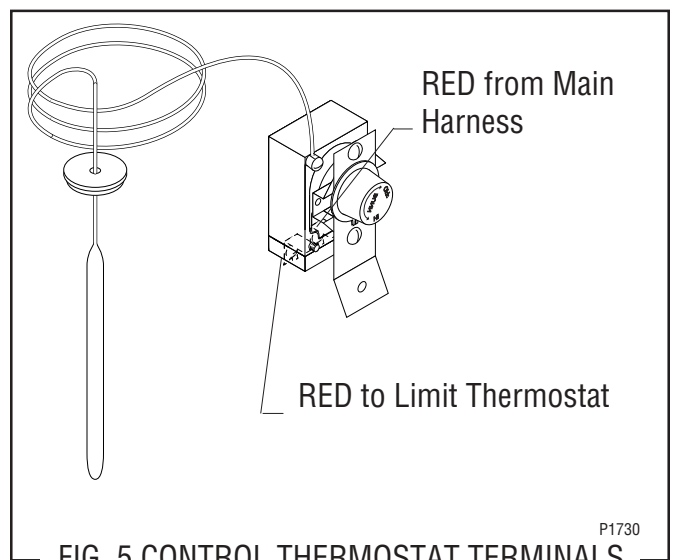

SERVICE (cont.)
FUSE AND FUSE HOLDER

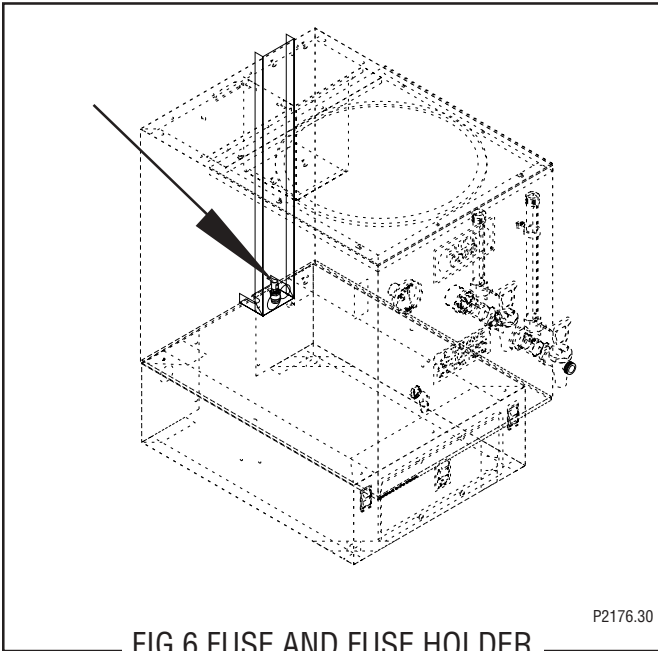

FIG.6 FUSE AND FUSE HOLDER

Location:

The fuse and fuse holder are located on the rear of the urn behind the rear utility cover.

Test Procedures:

1. Disconnect the brewer from the power source.
2. Remove the cap and fuse from the fuse holder.
3. Remove fuse from the cap.
4. Check for continuity through the fuse.

If continuity is present as described, reinstall the fuse, the fuse is operating properly.

If continuity is not present as described replace the fuse.

Removal and Replacement:

Fuse:

1. Remove the cap from the fuse holder.
2. Remove fuse from the fuse holder, inspect, if blown discard.
3. Install new 5 amp fuse in the fuse holder.
4. Reinstall fuse holder cap.

Fuse Holder:

1. Disconnect the wires from the rear of the fuse holder.
2. Remove the nut securing the fuse holder to the component bracket.
3. Push fuse holder through the hole in the component bracket.
4. Install new fuse holder and fuse through the hole in the component bracket and secure with nut.
5. Refer to Fig. 7 and reconnect the wires.

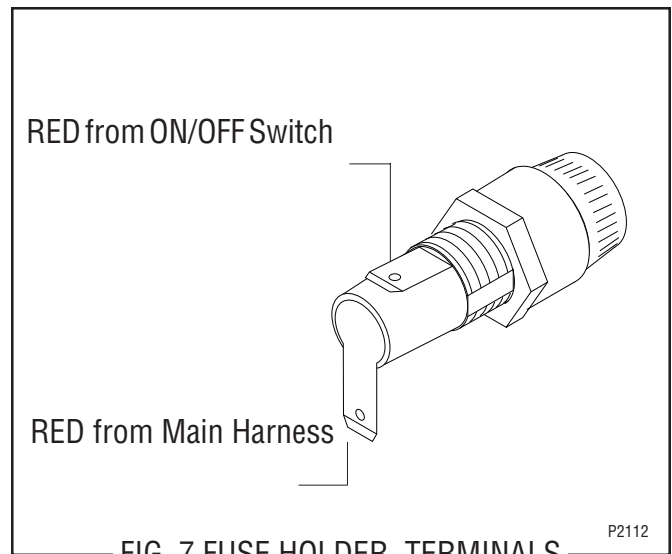

FIG. 7 FUSE HOLDER TERMINALS

SERVICE (cont.)
LIMIT THERMOSTAT

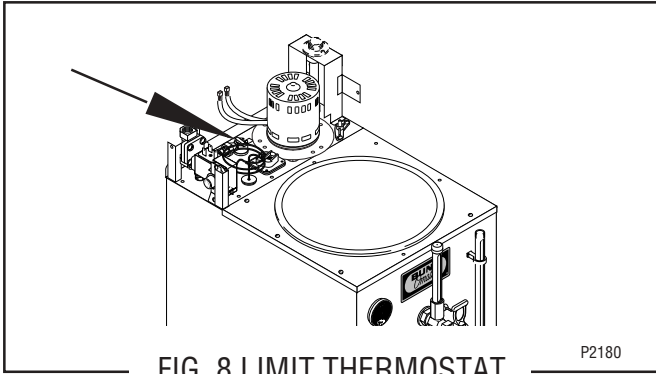

FIG. 8 LIMIT THERMOSTAT

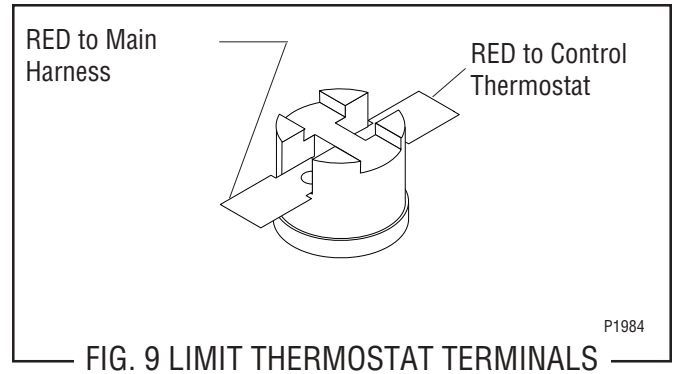

FIG. 9 LIMIT THERMOSTAT TERMINALS

Location:

The limit thermostat is located on the center rear of the component bracket behind the tank heater.

Test Procedures:

1. Disconnect the brewer from the power source.
2. Disconnect the red wires from the limit thermostat.
3. Check for continuity across the limit thermostat terminals with an ohmmeter.

If continuity is present as described, the limit thermostat is operating properly.

If continuity is not present as described, replace the limit thermostat.

Removal and Replacement:

1. Remove the wires from the limit thermostat terminals.
2. Carefully slide the limit thermostat out from under the retaining clip and remove the limit thermostat.
3. Carefully slide the new limit thermostat into the retaining clip.
4. Refer to Fig. 9 and reconnect the wires.

SERVICE (cont.)

LIQUID LEVEL BOARD AND LEVEL PROBE

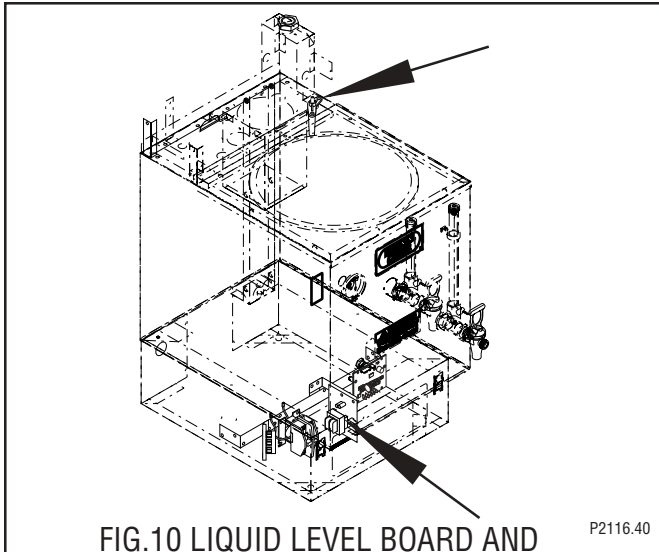

FIG.10 LIQUID LEVEL BOARD AND
LEVEL PROBE

P2116.40

Location:

The liquid level board is located behind the lower front access panel, to the right of center on the component bracket. The level probe is located on the right front of the upper component bracket.

Test Procedures:

1. Disconnect the brewer from the power source.
2. Disconnect the blue wire (T1) and the pink wire (T4).
3. Check for 230 volts ac across terminals (T2) and (T3) with the ON/OFF switch in the "ON" position.
4. Disconnect the brewer from the power source.

If voltage is present as described, proceed to #5.

If voltage is not present as described, refer to wiring diagram and check the brewer wiring harness.

5. Reconnect the blue wire to T1 on the liquid level board.
6. Carefully connect a piece of insulated jumper wire to T4. Keep the other end of this wire away from any metal surface of the brewer.

7. Touching the free end of the jumper to the brewer's frame simulates a "FULL" condition, preventing jumper from touching the brewer's frame simulates "NEED WATER" condition. Connect the brewer to the power source, simulate each condition while measuring the voltage between T1 and T3 on the liquid level board. The indication should be 0 volts with jumper touching the frame and 230 volts ac not touching the frame. Repeat these several times. Keep in mind there is an approximate five second delay for output to stabilize.
8. Disconnect the brewer from the power source and remove the jumper wire from T4.

If voltage is present as described, liquid level board is operating properly, proceed to #9.

If voltage is not present as described, replace the liquid level board.

9. Reconnect the pink wire to T4.
10. Remove the two #8-32 screws securing the level probe to the component bracket.
11. Gently pull the probe out of the component bracket and inspect for corrosion. Replace if necessary.
12. Place the probe so that neither end is in contact with any metal surface of the brewer.
13. Connect the brewer to the power source and simulate the "FULL" and "NEED WATER" conditions by touching the end of the probe to any metal surface of the brewer. Measure the voltage between T1 and T3 on the liquid level board. The indication should be 0 volts with the probe touching the frame and 230 volts ac not touching the frame. Keep in mind there is an approximate delay of five seconds for output to stabilize.
14. Disconnect the brewer from the power source.

If voltage is present as described, reinstall the level probe, the liquid level board and level probe are operating properly.

If voltage is not present as described, check the pink wire on the level probe from liquid level board T4.

SERVICE (cont.)

LIQUID LEVEL BOARD AND LEVEL PROBE (cont.)

Removal and Replacement:

1. Remove all wires from the liquid level board.
2. Remove the #10-32 screw and flat washer securing the protective shield to the component bracket.
3. Remove the #10-32 screw and internal tooth lockwasher securing the liquid level board to the component bracket.
4. Remove liquid level board and discard.
5. Install new liquid level board on component bracket and secure with a #10-32 screw and internal tooth lockwasher.
6. Install protective shield and secure with #10-32 screw and flat washer.
7. Refer to Fig. 11 and reconnect the wires.

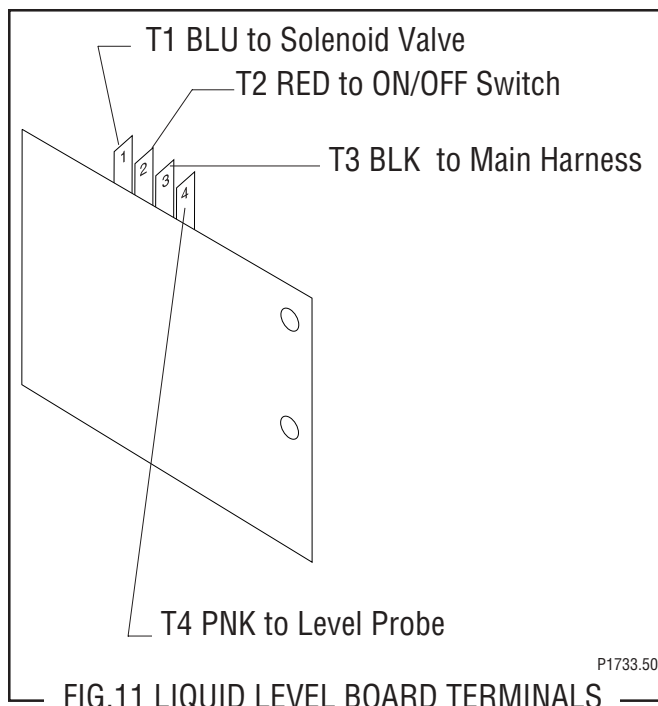

FIG.11 LIQUID LEVEL BOARD TERMINALS

SERVICE (cont.)

ON/OFF SWITCH

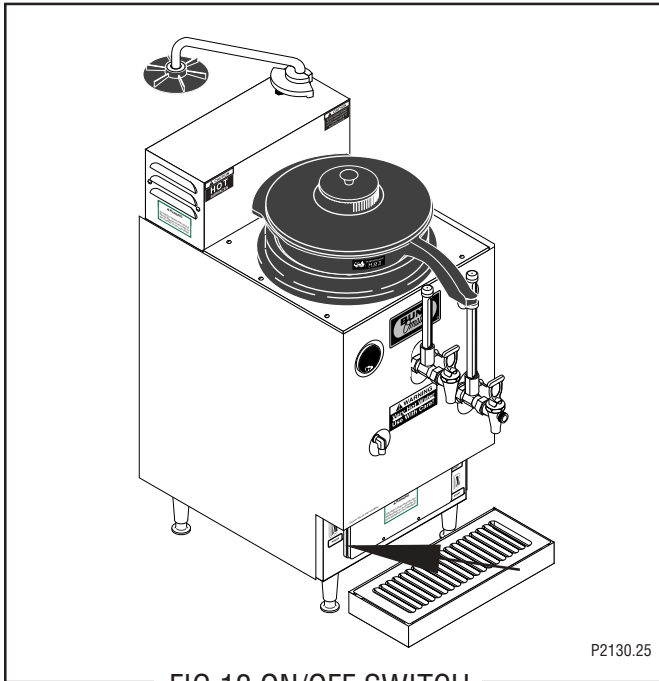

FIG.12 ON/OFF SWITCH

Location:

The ON/OFF switch is located on the left side of the lower front access panel.

Test Procedures:

1. Disconnect the brewer from the power source.
2. Remove the red wire on the ON/OFF switch from the fuse holder and the black wire from the main harness.
3. Connect the brewer to the power source. Check the voltage across the removed wires with a voltmeter. The indication must be 230 volts ac.
4. Disconnect the brewer from the power source.

If voltage is present as described, reconnect the wires and proceed to #5

If voltage is not present as described, refer to the wiring diagram and check the brewer wiring harness.

5. Disconnect all wires on the ON/OFF switch.
6. Check for continuity across the center terminal (2) and the lower terminal (1) when the switch is in the "ON" (upper) position. Continuity must not present when the switch is in "OFF" (lower) position.

If continuity is present as described, the switch is operating properly.

If continuity is not present as described, replace the switch.

Removal and Replacement:

1. Remove the wires from the switch terminals.
2. Compress the clips on the back side of the switch and gently push them through the opening.
3. Push the new switch into the opening and spread the clips to hold switch.
4. Refer to Fig. 13 and reconnect the wires.

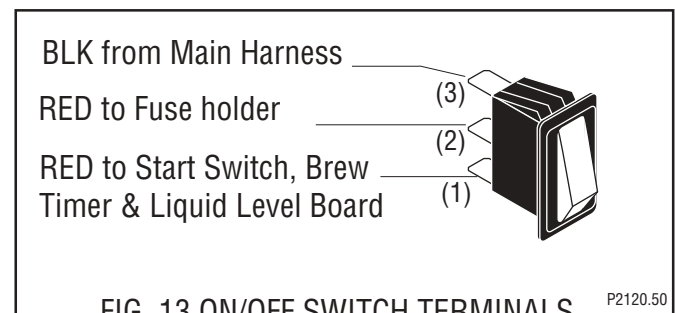
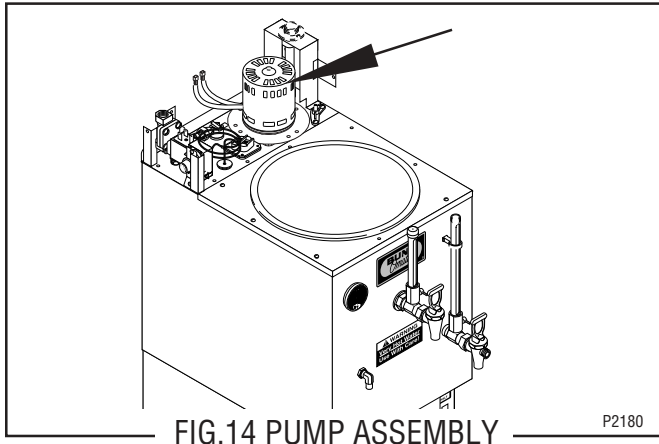

FIG. 13 ON/OFF SWITCH TERMINALS

SERVICE (cont.)

PUMP ASSEMBLY



3. Disengage the fill tube (1) from the pump assembly (4).
4. Remove the four #8-32 screws (6) securing the pump assembly (4) to the component bracket (7).
5. Remove pump assembly (4).
6. Remove pump gasket (5) and inspect, replace if necessary.
7. Position gasket (5) on component bracket (7).
8. Install new pump assembly (4) on component bracket (7) and secure with four #8-32 screws (6).
9. Install fill tube (1) on pump assembly (4).
10. Slide clamp (3) down into position on the fill tube (1) and tighten screw (2).
11. Refer to Fig. 15 and reconnect the wires.

Location:

The pump is located on the right of the upper component bracket.

Test Procedures:

1. Disconnect the brewer from the power source.
2. Disconnect the black wire from the black lead on the pump and the red wire from the black lead on the pump.
3. With a voltmeter, check the voltage across the black wire and the red wire with the swing arm switch plunger depressed. Connect the brewer to the power source. The indication must be 230 volts ac.
4. Disconnect the brewer from the power source.

If voltage is present as described, reconnect the wires to the pump. Install swing spout and position over the reservoir. Place the ON/OFF in the "ON" (upper) position and push the start switch and release. If pump does not run, replace the pump.

If voltage is not present as described, refer to the wiring diagrams and check the brewer wiring harness.

Removal and Replacement (Refer to Fig. 15):

1. Disconnect the wires from the pump assembly.
2. Loosen the #8-32 screw (2) securing the clamp (3) on the fill tube (1) and slide the clamp (3) up the fill tube (1).

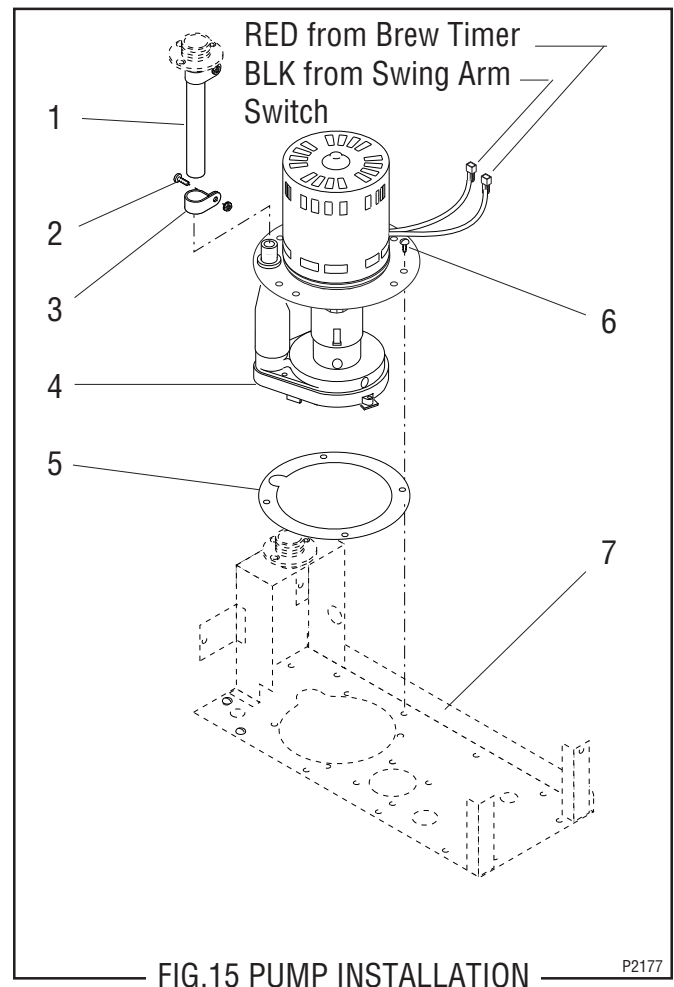

SERVICE (cont.)

SELECTOR SWITCH (HALF BATCH OPTION)

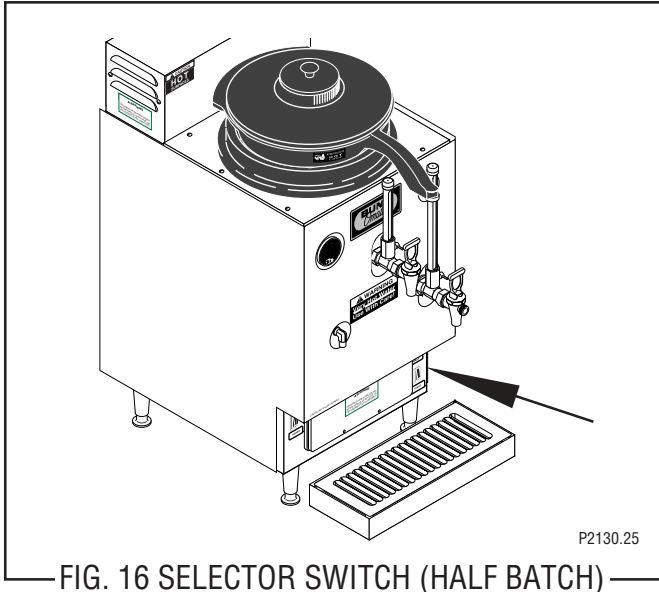

FIG. 16 SELECTOR SWITCH (HALF BATCH)

Location:

The selector switch is located to the right of the front access panel above the start switch.

Test Procedures:

1. Disconnect the brewer from the power source.
2. Disconnect the wires from the switch terminals.
3. Check for continuity across the switch terminals with the switch in the "CLOSED" (lower - half) position. Continuity must not be present when the switch is in the "OPEN" (upper - full) position.

If continuity is present as described, the switch is operating properly.

If continuity is not present as described, replace the switch.

Removal and Replacement:

1. Remove the wires from the switch terminals.
2. Compress the clips on the back side of the switch and gently push them through the opening.
3. Push the new switch into the opening and spread the clips to hold switch.
4. Refer to Fig. 17 and reconnect the wires.

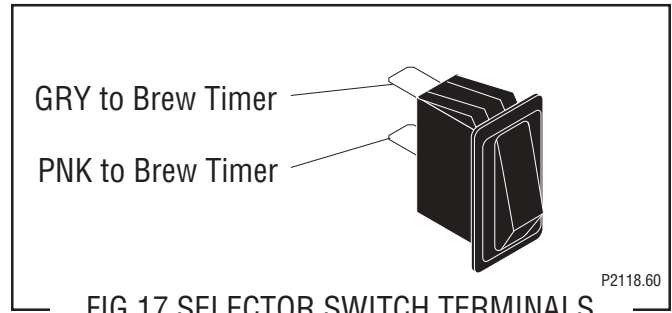
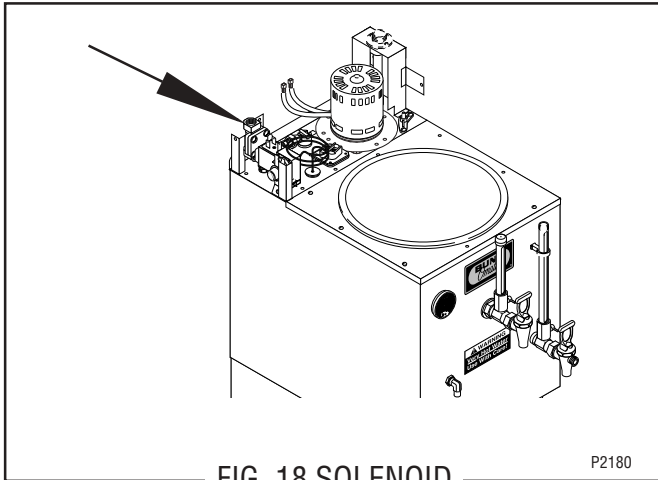

FIG.17 SELECTOR SWITCH TERMINALS

SERVICE (cont.)

SOLENOID



Location:

The solenoid is mounted on the upper left rear of the component bracket.

Test Procedures:

1. Drain 1/2 gallon of water from the faucet in order to activate the probe.
2. Disconnect the brewer from the power source.
3. Place the ON/OFF switch in the ON position.
4. Disconnect the blue wire from the liquid level board T1 and the black wire from the main harness to the solenoid. With a voltmeter, check the voltage across the blue wire and the black wire. Connect the brewer to the power source. After an approximate 5 second delay, the indication must be 230 volts ac.
5. Disconnect the brewer from the power source.

If voltage is present as described, proceed to #6.

If voltage is not present as described, refer to the brewer wiring diagram and check the wiring harness.

6. Check for continuity across the solenoid valve coil terminals.

If continuity is present as described, reconnect the wires to the solenoid.

If continuity is not present as described, replace the solenoid valve.

7. Check the solenoid valve for coil action. Connect the dispenser to the power source. Listen carefully in the vicinity of the solenoid valve for a "clicking" sound as the coil magnet attracts.

If the sound is heard as described and water will not pass through the solenoid valve, there may be a blockage in the water line before the solenoid valve or, the solenoid valve may require inspection for wear, and removal of waterborne particles.

If the sound is not heard as described, replace the solenoid valve.

Removal and Replacement:

1. Remove all wires from the solenoid valve.
2. Turn off the water supply to the brewer.
3. Disconnect the water inlet line from the connector on the solenoid valve.
4. Remove solenoid, connectors, and tank inlet tube as an assembly.
5. Remove the tank inlet tube grommet and discard.
6. Install new tank inlet tube grommet.
7. Install new solenoid assembly.
8. Install water inlet tube to connector on the solenoid.
9. Turn on the water supply to the brewer.
10. Refer to Fig. 19 and reconnect the wires.

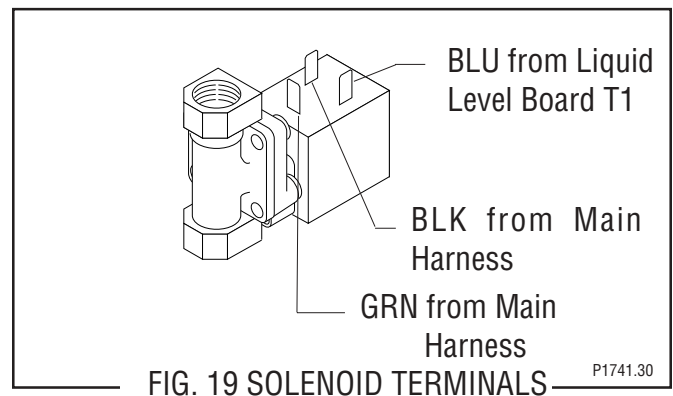

SERVICE (cont.)

START SWITCH (BREW)

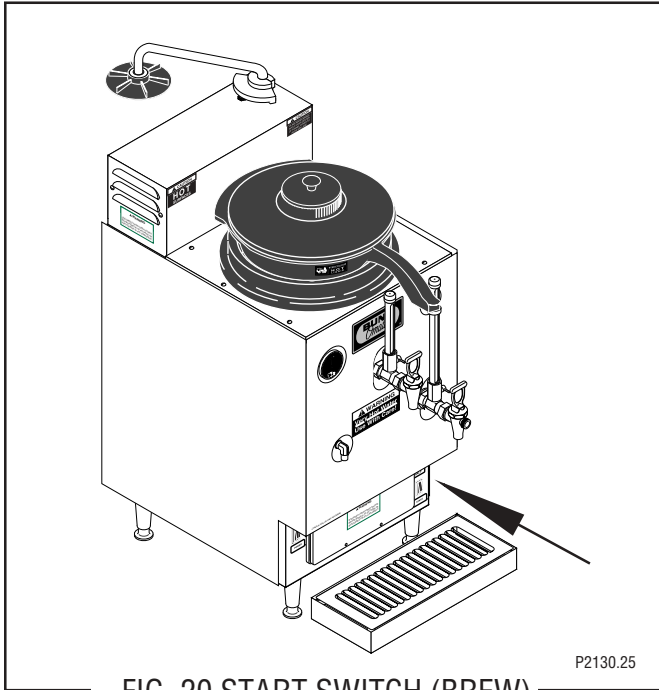

FIG. 20 START SWITCH (BREW)

P2130.25

Location:

The brew start switch is located on the lower right of the front access panel, beneath the selector switch.

Test Procedures:

1. Disconnect the brewer from the power source.
2. Remove the wires from the start switch terminals.
3. Check for continuity across the switch terminals when the switch is held in the lower position. Continuity must not be present when the switch is in the upper position.

If continuity is present as described, reconnect the wires the switch is operating properly.

If continuity is not present as described, replace the switch.

Removal and Replacement:

1. Remove the wires from the switch terminals.
2. Compress the clips on the back side of the switch and gently push them through the opening.
3. Push the new switch into the opening and spread the clips to hold switch.
4. Refer to Fig. 21 and reconnect the wires.

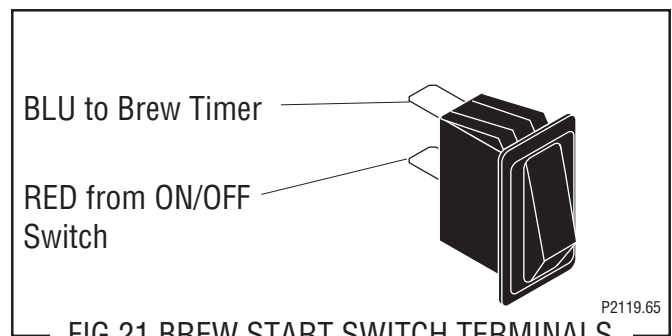

FIG.21 BREW START SWITCH TERMINALS

P2119.65

SERVICE (cont.)

SWING ARM SWITCH

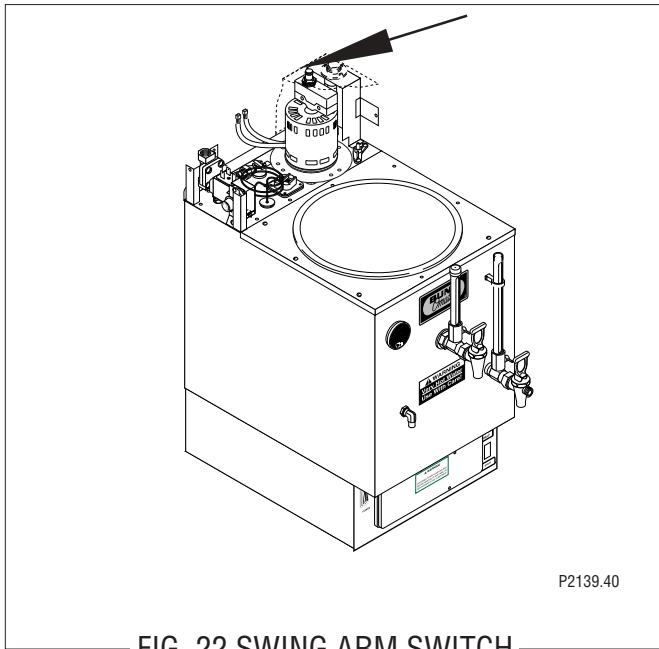

FIG. 22 SWING ARM SWITCH

Location:

The swing arm switch is attached to the cupola cover.

Test Procedures:

1. Disconnect the brewer from the power source.
2. Remove the cupola cover end caps, swing spout and cupola cover.
3. Disconnect the two black wires connected to the switch.
4. Check for continuity across the terminals on the switch.
5. Continuity should be present when switch plunger is depressed.

If continuity is present as described, the switch is operating properly.

If continuity is not present as described, replace the switch.

Removal and Replacement:

NOTE: Measure the distance from the top of the switch plunger to the hood cover. The same distance is needed when the new switch is installed.

1. Remove nut securing switch to hood cover and remove switch.
2. Install new switch. Refer to Fig. 23 and reconnect the wires.
3. Install all panels.
4. Test action of swing arm and switch for activation.
5. Adjust switch assembly up or down as needed for proper operation.

NOTE: Do not remove cam assembly from swing spout.

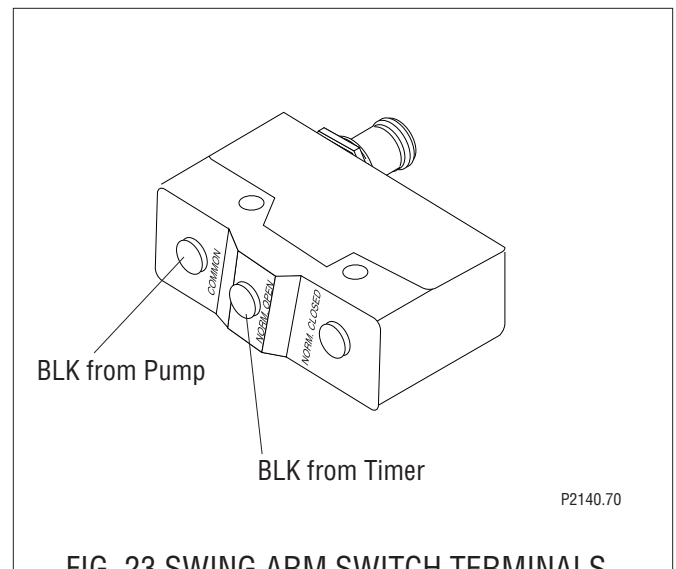

FIG. 23 SWING ARM SWITCH TERMINALS

SERVICE (cont.)

TANK HEATER

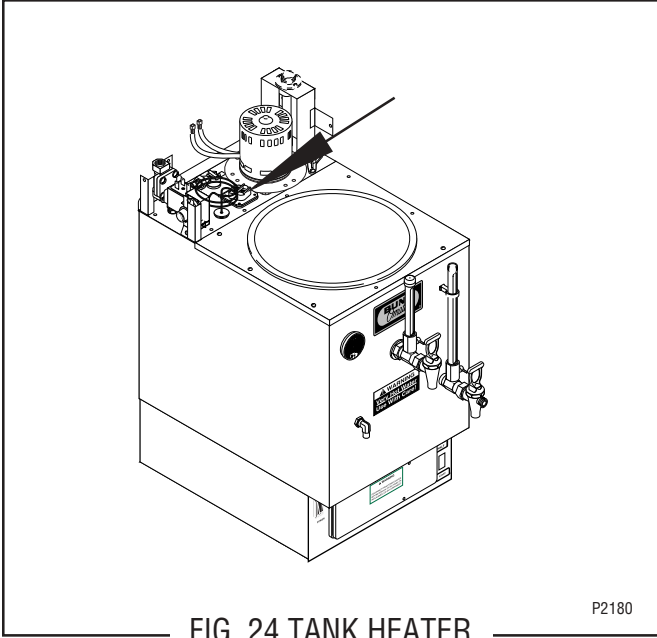

FIG. 24 TANK HEATER

P2180

Location:

The tank heater is located on the front center of the upper component bracket.

Test Procedures:

1. Disconnect the brewer from the power source.
2. Disconnect the wires from the tank heater.
3. Check for continuity across the tank heater terminals.

If continuity is present as described, tank heater is operating properly.

If continuity is not present as described, replace the tank heater.

Removal and Replacement:

1. Remove the thermal fuses from the tank heater.
2. Remove the four #8-32 screws securing the tank heater to the component bracket.
3. Remove tank heater and gasket.
4. Position new tank heater and gasket on the component bracket and secure with four #8-32 screws.
5. Refer to Fig. 25 and reconnect the wires.

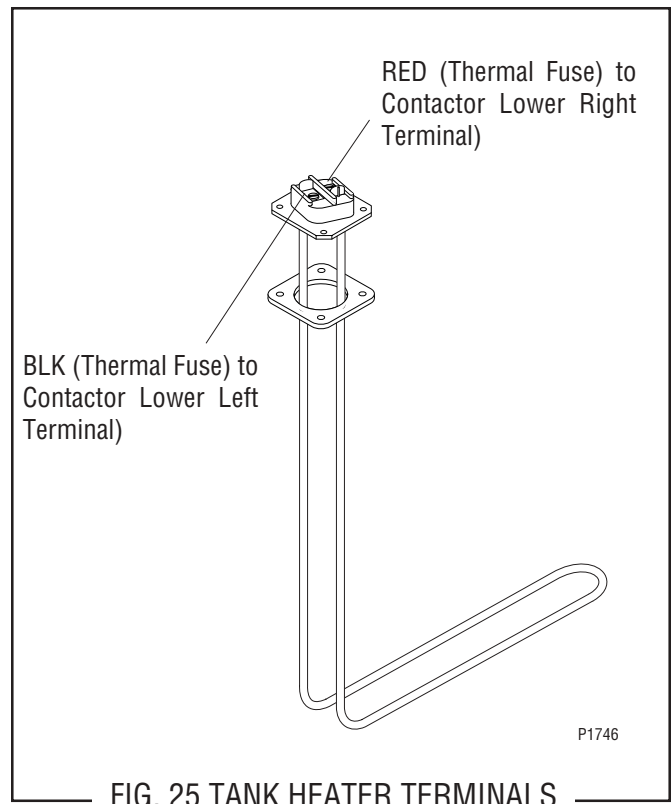

BLK (Thermal Fuse) to
Contactor Lower Left
Terminal)

RED (Thermal Fuse) to
Contactor Lower Right
Terminal)

P1746

FIG. 25 TANK HEATER TERMINALS

SERVICE (cont.)

THERMAL FUSES

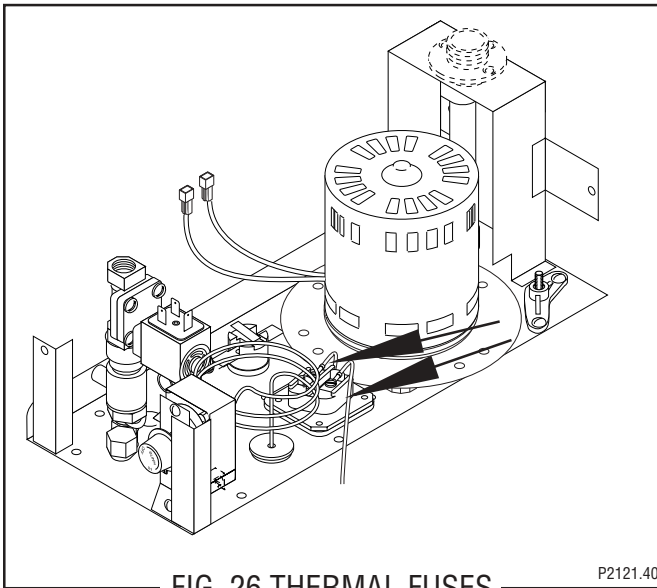

Location:

The thermal fuses are mounted between the tank heater terminals and the contactor terminals.

Test Procedures:

1. Disconnect the brewer from the power source.
2. Disconnect the thermal fuse from the tank heater terminal and the contactor lead.
3. Check for continuity across the terminals on the ends of each thermal fuse.

If continuity is present as described, the thermal fuse is operating properly.

If continuity is not present as described, replace the thermal fuse.

Removal and Replacement:

1. Disconnect the thermal fuse from the tank heater terminal and the contactor lead and discard.
2. Connect the new thermal fuse to the tank heater terminal and the contactor lead.

SERVICE (cont.)
TIMER

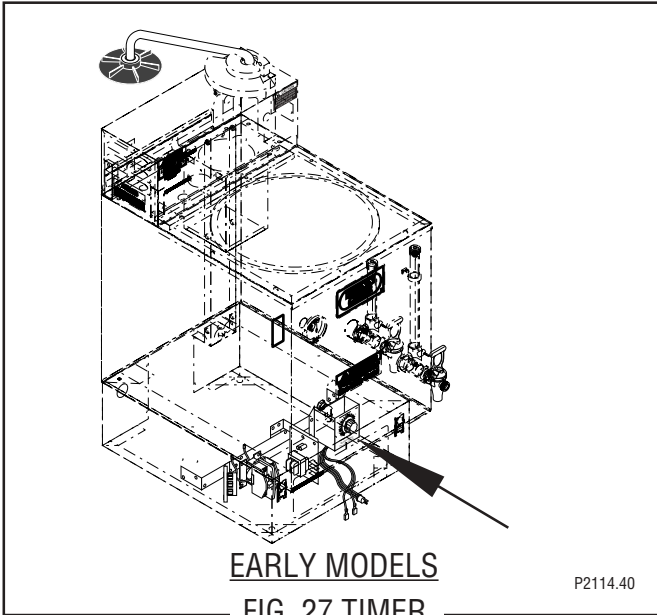

Location:

The timer is located behind the front access panel on the right side of the component bracket.

Test Procedures:

1. Disconnect the brewer from the power source.
2. Disconnect the polarized, three pin connector from the brewer main harness and rotate the brew timer dial fully counterclockwise.
3. With a voltmeter check the voltage across sockets P2 and P3 (black and red wire) of the female connector on the main wiring harness when the "ON/OFF" switch is in the "ON" (upper) position. Connect the brewer to the power source. The indication must be 230 volts ac.
4. Disconnect the brewer from the power source. If voltage is present as described, proceed to #5. If voltage is not present as described, refer to the wiring diagram and check the brewer wiring harness.
5. With a voltmeter check the voltage across the sockets P1 and P2 (blue and black wires) of the female connector on the main harness when the "ON/OFF" switch is in the "ON" (upper) position and the start switch pressed. Connect the brewer to the power source. The indication must be 230 volts ac.
6. Disconnect the brewer from the power source.
7. Reconnect the three pin connector from the main wiring harness to the connector on the timer.

If voltage is present as described, proceed to #8.
If voltage is not present as described, refer to the wiring diagram and check the brewer wiring harness.

8. Disconnect the black and white wires to the swing arm switch and pump leads.
9. With a voltmeter check the voltage across the black and white wires when the "ON/OFF" switch is in the "ON" (upper) position and the start switch pressed to the start position and released. Connect the brewer to the power source. The indication must be 230 volts ac.

If voltage is present as described, the brew timer is operating properly. Reset the timer dial as required, to obtain the desired brew volume.

If voltage is not present as described, replace the timer.

Removal and Replacement:

1. Disconnect the male connector on the timer from the female connector on the main wiring harness.
2. Disconnect the timer leads from the swing arm switch lead and pump lead.
3. Disconnect the three pin connector from the HALF/FULL batch selector switch to the three pin plug on the brew timer.
4. Remove the two #8-32 screws securing the brew timer to the component bracket and remove timer.
5. Position new timer on the component bracket and secure with two #8-32 screws.
6. Refer to Fig. 30 and reconnect the wires.

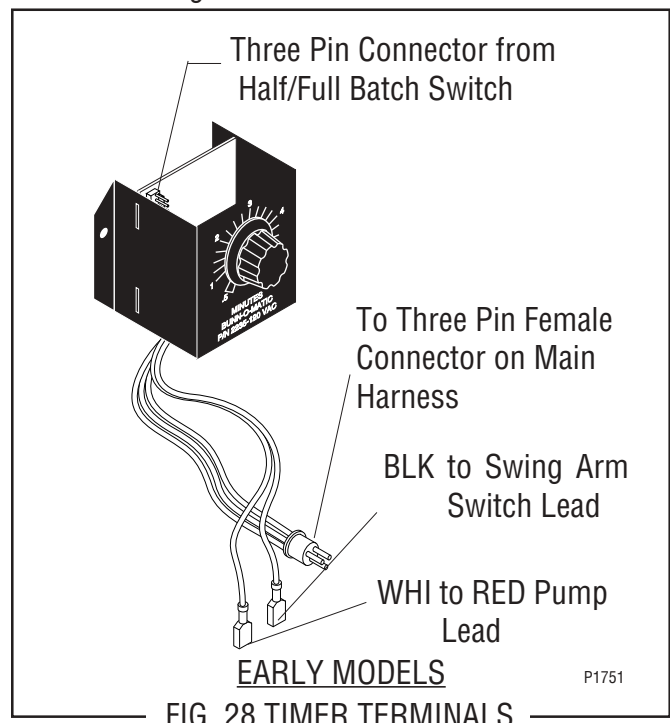

SERVICE (cont.)

DIGITAL BREW TIMER (Late Models)

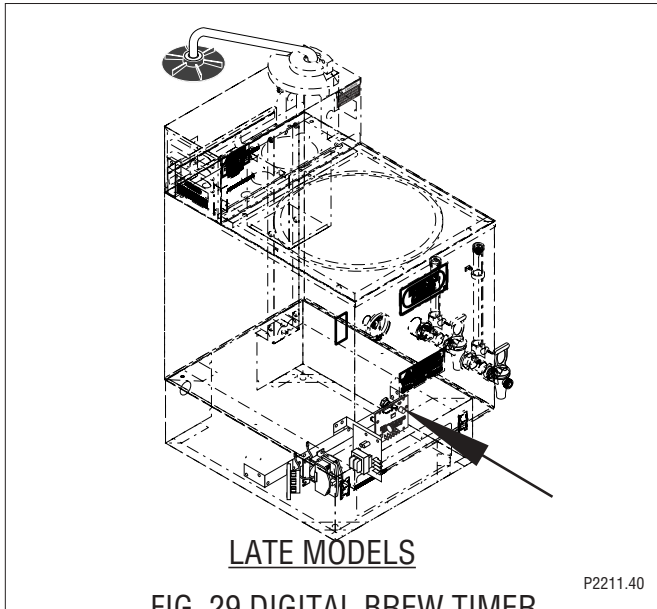

Location:

The timer is located inside the front of the trunk on the top of the component bracket.

Test Procedure.

NOTE: Do not remove or install wires while timer board is installed. Pressure applied to one side may cause damage to the board.

1. Disconnect the brewer from the power source and remove the front access panel.
2. Remove the two #8-32 screws securing circuit board to the mounting bracket.
3. Remove circuit board and spacers (as required).
4. With a voltmeter, check the voltage across terminals TL1 and TL2 when the "ON/OFF" switch is in the "ON" position. Connect the brewer to the power source. The indication must be 230 volts ac.
5. Disconnect the brewer from the power source.

If voltage is present as described, proceed to #6.
If voltage is not present as described, refer to the *Wiring Diagrams* and check the brewer wiring harness.

6. With a voltmeter, check the voltage across terminals TL1 and TL4 when the "ON/OFF" switch is in the "ON" position. Connect the brewer to the power source. The indication must be 0 volts.

If voltage is as described, proceed to #7.

If voltage is not as described, disconnect the brewer from the power source and replace the timer.

7. With a voltmeter, check the voltage across terminals TL1 and TL4 when the "ON/OFF" switch is in the "ON" position. Connect the brewer to the power source and press the "START" switch. The indication must be 230 volts ac.

If voltage is present as described, the brew timer is operating properly. Reset the timer as required, to obtain the desired brew volume.

If voltage is not present as described, disconnect the brewer from the power source and replace the timer.

Removal and Replacement:

1. Remove the two #8-32 screws securing circuit board to the mounting bracket.
2. Remove circuit board and spacers (as required).
3. Remove all wires from the timer.
4. Attach all wires to the replacement timer board prior to installation to the component mounting bracket. Refer to FIG. 30 when reconnecting the wires.
5. Install new circuit board with spacers (as required) to the component mounting bracket.
6. Adjust the timer as described below.

Timer Setting:

NOTE: Prior to setting or modifying volumes, check that the brewer is connected to water supply, the tank is properly filled, and a funnel support, funnel and funnel cover are in place.

NOTE: All volume settings must be done with the swing spout shield installed.

1. **Modifying brew volumes.** To modify a brew volume, first check that the SET/LOCK switch is in the "SET" position on the circuit board.

To increase a brew volume, place the ON/OFF switch in the "ON" position, press and hold the START switch until you see three breaks in the water stream from the swing arm. Release the switch and press it again one or more times. (Failure to release the switch

SERVICE (cont.)

DIGITAL BREW TIMER (Late Models)

within two seconds after the third break in the water stream causes the volume setting to be aborted and previous volume setting will remain in memory.) Each time the switch is pressed, two seconds are added to the brew time period. Allow the brew cycle to finish in order to verify that the desired volume has been achieved.

To decrease a brew volume, place the ON/OFF switch in the “ON” position, press and release the START switch once for every two-second interval to be removed from the total brew time period; then immediately press and hold down the START switch until you see three breaks in the water stream from the swing arm. Release the switch. (Failure to release the switch within two seconds after the third break in the water stream causes the volume setting to be aborted and previous volume setting will remain in memory). Allow the brew cycle to finish in order to verify that the desired volume has been achieved.

2. Setting brew volumes. To set a brew volume, first check that the SET/LOCK switch is in the “SET” position. Place the ON/OFF switch in the “ON” position, press and hold the START switch until you see three breaks in the water stream from the swing arm and then release the switch. (Failure to release the switch within two seconds after the third break in the water stream causes the volume setting to be aborted and previous volume setting will remain in memory.)

View the level of the liquid being dispensed. When the desired level is reached, turn the ON/OFF switch to “OFF”.

NOTE: The brewer remembers this volume and will continue to brew batches of this size until the volume setting procedure is repeated.

NOTE: When brewing coffee, volume will decrease due to absorption by the coffee grounds.

NOTE: Half-Batch and full batch settings must each be set separately.

3. Setting programming disable feature. If it becomes necessary to prevent anyone from changing brew time once programmed, you can set the SET/LOCK switch to the “LOCK” position. This will prevent any further programming until switch is once again put into the “SET” position.

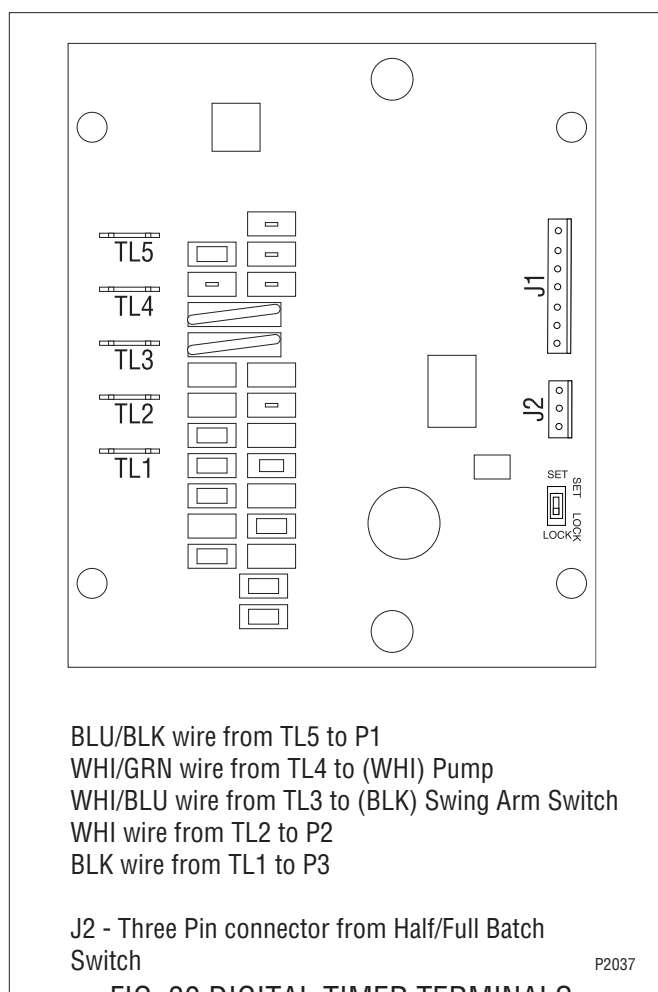

FIG. 30 DIGITAL TIMER TERMINALS

SCHEMATIC WIRING DIAGRAM SRUA - CE

