

BUNN®

WL2

WARMER

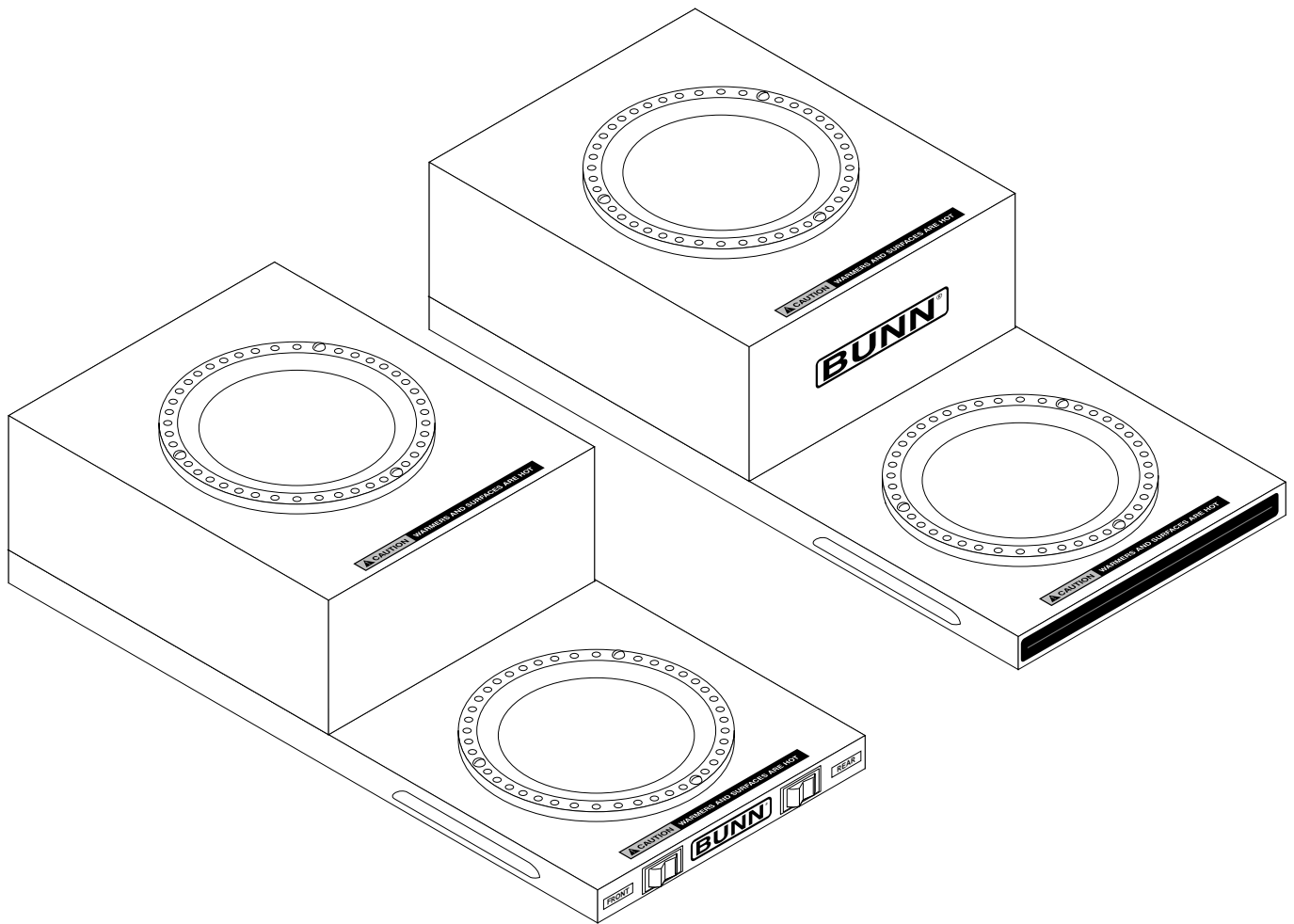

ILLUSTRATED PARTS CATALOG

Designs, materials, weights, specifications, and dimensions for equipment or replacement parts are subject to change without notice.

BUNN-O-MATIC CORPORATION

POST OFFICE BOX 3227

SPRINGFIELD, ILLINOIS 62708-3227

PHONE: (217) 529-6601 FAX: (217) 529-6644

WARRANTY

Bunn-O-Matic Corp. ("Bunn") warrants the equipment manufactured by it to be commercially free from defects in material and workmanship existing at the time of manufacture and appearing within one year from the date of installation. In addition:

1.) Bunn warrants electronic circuit and/or control boards to be commercially free from defects in material and workmanship for three years from the date of installation.

2.) Bunn warrants the compressor on refrigeration equipment to be commercially free from defects in material and workmanship for two years from the date of installation.

3.) Bunn warrants that the grinding burrs on coffee grinding equipment will grind coffee to meet original factory screen sieve analysis for three years from date of installation or for 30,000 pounds of coffee, whichever comes first.

This warranty does not apply to any equipment, component or part that was not manufactured by Bunn or that, in Bunn's judgement, has been affected by misuse, neglect, alteration, improper installation or operation, improper maintenance or repair, damage or casualty.

THE FOREGOING WARRANTY IS EXCLUSIVE AND IS IN LIEU OF ANY OTHER WARRANTY, WRITTEN OR ORAL, EXPRESS OR IMPLIED, INCLUDING, BUT NOT LIMITED TO, ANY IMPLIED WARRANTY OF EITHER MERCHANTABILITY OR FITNESS FOR A PARTICULAR PURPOSE. The agents, dealers or employees of Bunn are not authorized to make modifications to this warranty or to make additional warranties that are binding on Bunn. Accordingly, statements by such individuals, whether oral or written, do not constitute warranties and should not be relied upon.

The Buyer shall give Bunn prompt notice of any claim to be made under this warranty by telephone at (217) 529-6601 or by writing to Post Office Box 3227, Springfield, Illinois, 62708-3227. If requested by Bunn, the Buyer shall ship the defective equipment prepaid to an authorized Bunn service location. If Bunn determines, in its sole discretion, that the equipment does not conform to the warranty, Bunn shall repair the equipment with no charge for parts during the warranty period and no charge for labor by a Bunn Authorized Service Representative during the warranty period. If Bunn determines that repair is not feasible, Bunn shall, at its sole option, replace the equipment or refund the purchase price for the equipment.

THE BUYER'S REMEDY AGAINST BUNN FOR THE BREACH OF ANY OBLIGATION ARISING OUT OF THE SALE OF THIS EQUIPMENT, WHETHER DERIVED FROM WARRANTY OR OTHERWISE, SHALL BE LIMITED, AS SPECIFIED HEREIN, TO REPAIR OR, AT BUNN'S SOLE OPTION, REPLACEMENT OR REFUND.

In no event shall Bunn be liable for any other damage or loss, including, but not limited to, lost profits, lost sales, loss of use of equipment, claims of Buyer's customers, cost of capital, cost of down time, cost of substitute equipment, facilities or services, or any other special, incidental or consequential damages.

TABLE OF CONTENTS

WARMER ASSEMBLY (without Fresh Light) 4
WARMER ASSEMBLY (with Fresh Light) 8

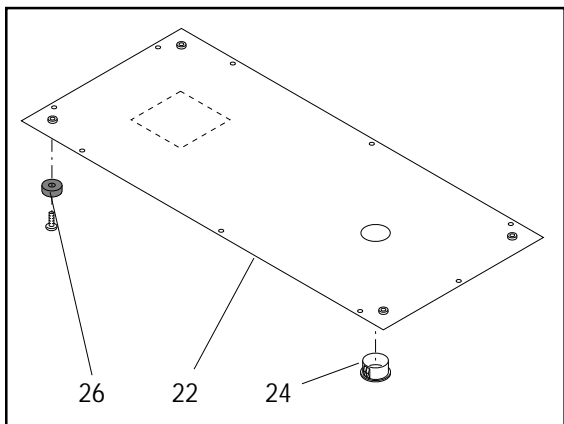
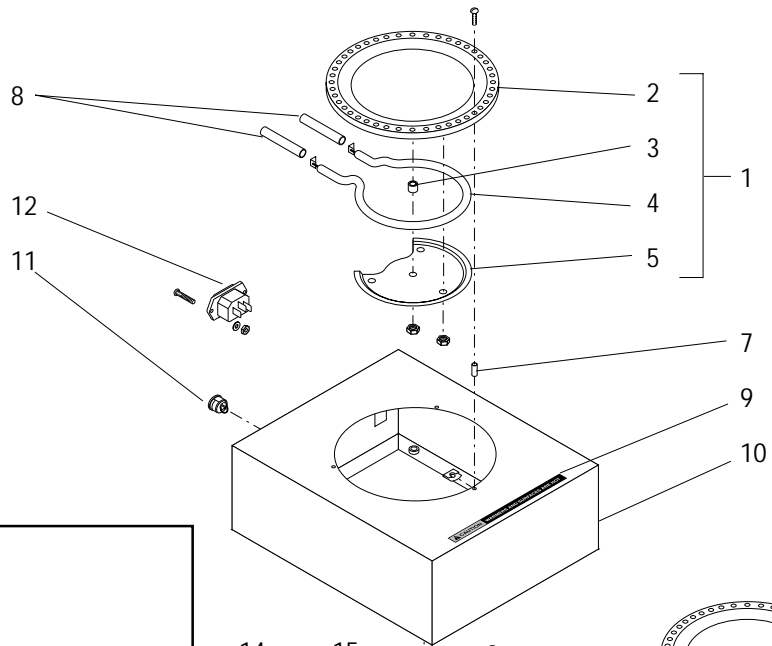

First Type-One Piece Floor Without Adjustable Legs

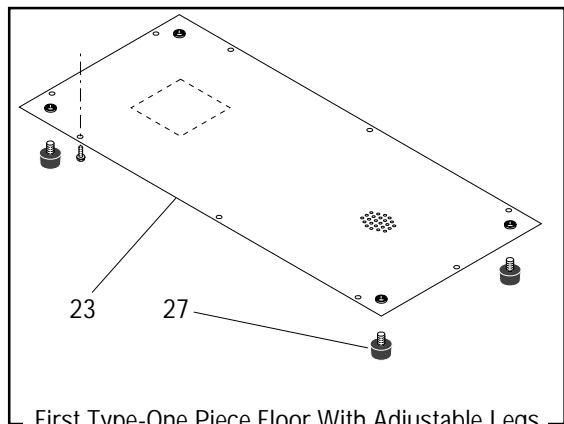

First Type-One Piece Floor With Adjustable Legs

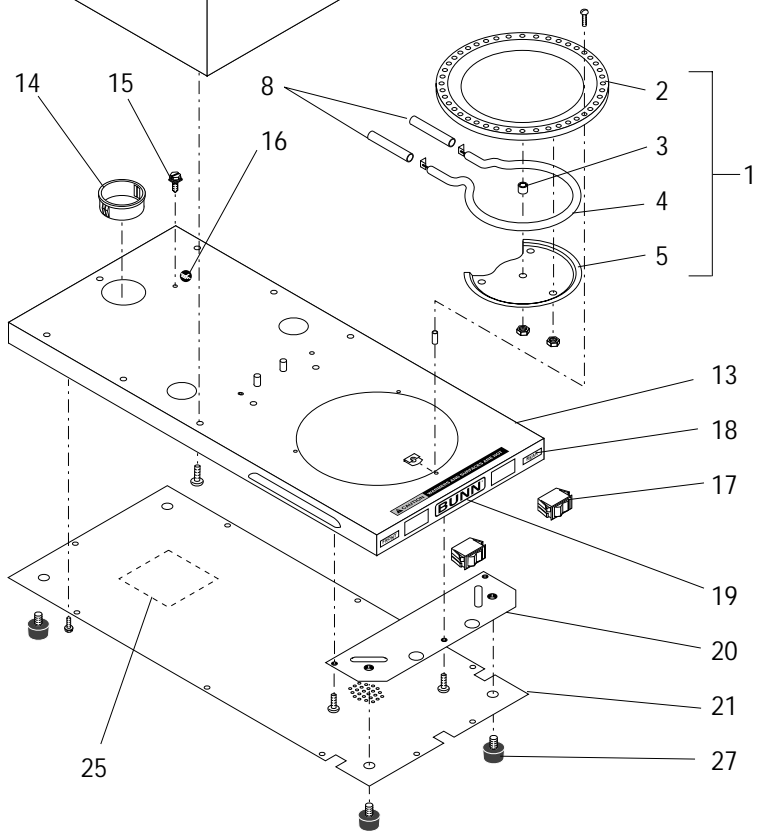

WARMER ASSEMBLY (without Fresh Light)

ITEM	PART NO.	QTY.	DESCRIPTION
1	11440.0006	2	Warmer Assy 100W, 120V (Includes items 2 thru 5)
	02817.0002	2	Warmer Assy, Upper, 100W, 240V (Includes items 2,4,5 & 6)
	02817.0001	2	Warmer Assy, Lower , 100W, 240V (Includes items 2,4,5 & 6)
	01304.0000	6	Screw, Pan Head #4-40 x .75"
	00916.0000	6	Fastener, J-Type #4-430
2	03656.0000	1	Warmer Dish
3	13042.0001	1	Spacer (120V only)
4	11443.0000	1	Warmer Element 100W, 120V
	01951.0000	1	Warmer Element 100W, 220V
5	05212.0000	1	Plate, Retaining
	00970.0000	2	Nut, Keps #8-32
6	21016.0024	1	Lead, Upper Warmer, GRN/YEL 7.0" (240V only)
	21016.0011	1	Lead, Lower Warmer, GRN/YEL 15.0" (240V only)
7	03666.0000	6	Spacer, Warmer Dish
8	-----	4	Tube, Silicone, .25" Dia x 1.88" (Order item 33)
9	12364.0000	2	Decal, CAUTION - WARMERS ARE HOT
10	-----	1	Housing, Warmer (Not serviced separately)
	02308.0000	7	Screw, Truss Head #8-32 x .38"
11	02423.0000	1	Bushing, Strain Relief (120V only)
12	01908.0000	1	Power Connector (240V only)
	01362.0000	2	Screw, OHV Slotted #4-40 x .50"
	01509.0000	2	Lockwasher, #4
	00937.0000	2	Nut #4-40
13	-----	1	Base, Warmer (Not serviced separately)
14	01593.0000	1	Bushing, Hole 1.50" Dia.
15	02337.0001	1	Screw, Ground #10 x .375" (120V only)
	01375.0000	1	Screw, Ground #10-32 x .50" (240V only)
	01512.0000	1	Lockwasher, #10
16	00824.0000	1	Decal, Ground (240V only)
17	11444.0000	2	Switch, Lighted (120V)
	11409.0000	2	Switch, Lighted (240V)
18	00786.0000	1	Decal, FRONT
	00787.0000	1	Decal, REAR
19	00851.0000	1	Decal, BUNN

] Not Illustrated

(Continued)

(Continued)

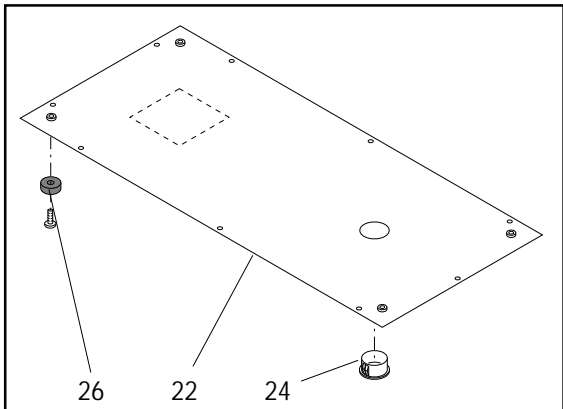
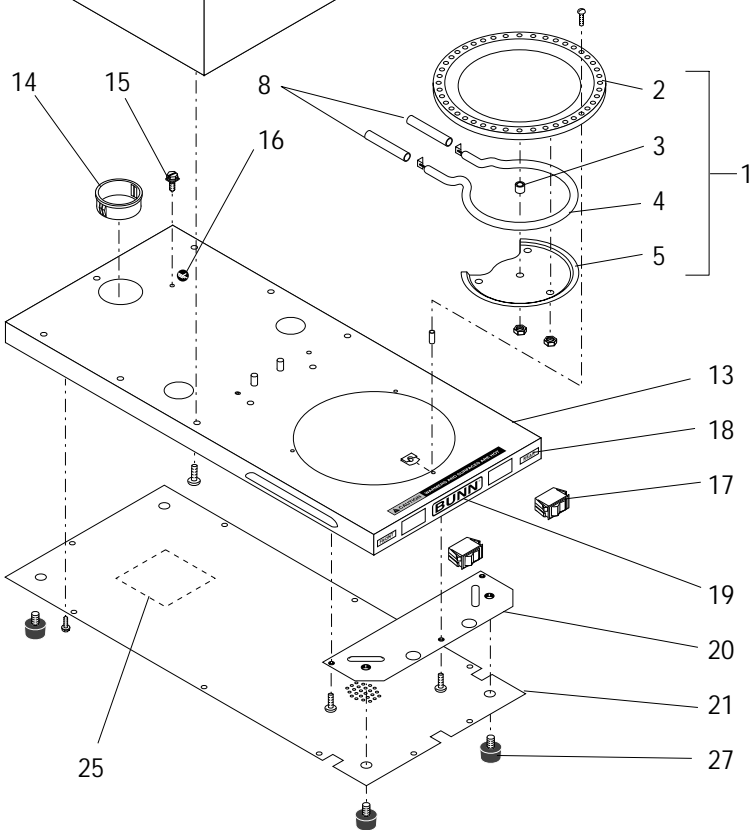
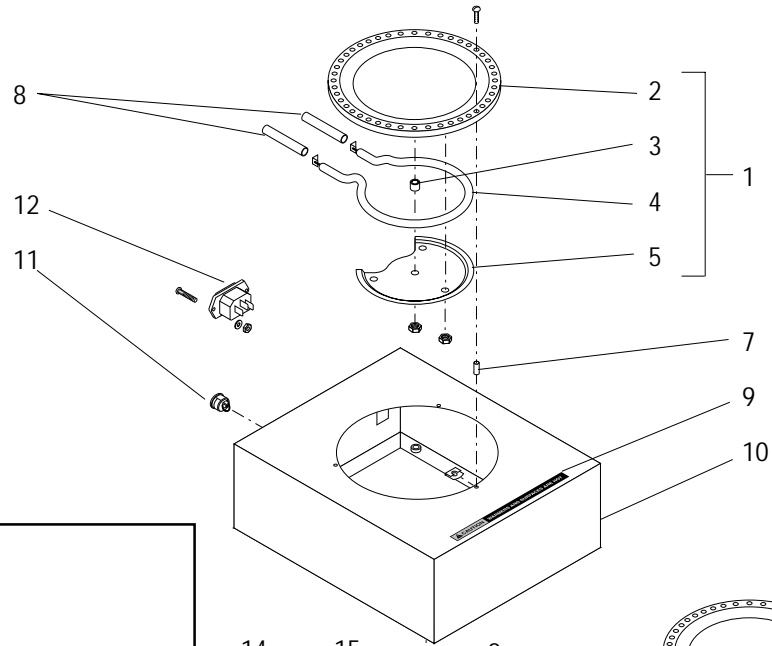

First Type-One Piece Floor Without Adjustable Legs

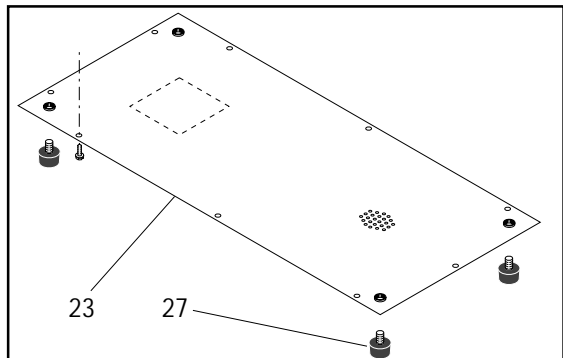

First Type-One Piece Floor With Adjustable Legs

WARMER ASSEMBLY (without Fresh Light)

ITEM	PART NO.	QTY.	DESCRIPTION
20	29244.0000	1	Plate, Foot Mounting (Second Type with two piece floor)
	01347.0000	3	Screw, Truss Head #6-32 x .38"
21	29212.0000	1	Plate, Bottom Base (Second Type with two piece floor)
	02332.0002	9	Screw, Hex Crimptite #6 x .38"
22	-----	1	Plate, Bottom Base (One piece floor without adjustable legs. Order 29260.0000 and four 25137.0000)
	02332.0002	9	Screw, Hex Crimptite #6 x .38"
23	29260.0000	1	Plate, Bottom Base (First Type. One piece floor with adjustable legs)
	02332.0002	9	Screw, Hex Crimptite #6 x .38"
24	03011.0000	1	Plug, Vent 1.0" Dia (First Type. One piece floor without adjustable legs)
25	00986.0000	1	Decal, WARNING-ELECTRICAL
26	11435.0000	4	Foot, Rubber (One piece floor without adjustable legs)
	02308.0000	4	Screw, Truss Head #8-32 x .38"
27	25137.0000	4	Foot, Adjustable
Items 28 thru 33 are not illustrated			
28	11449.0000	1	Harness, Main 120V
	11421.0000	1	Harness, Main 240V
29	02405.0000	1	Power Cord (120V only)
30	21016.0013	1	Lead, GRN 4.0" (240V only)
31	-----	2	Splice, Closed End (120V only)(Not serviced)
32	22568.0000	1	Foot Kit (Includes 4 Feet and screws)
33	04828.1001	-	Tube, Silicone .25" Dia x 24.0"

} Order item 32

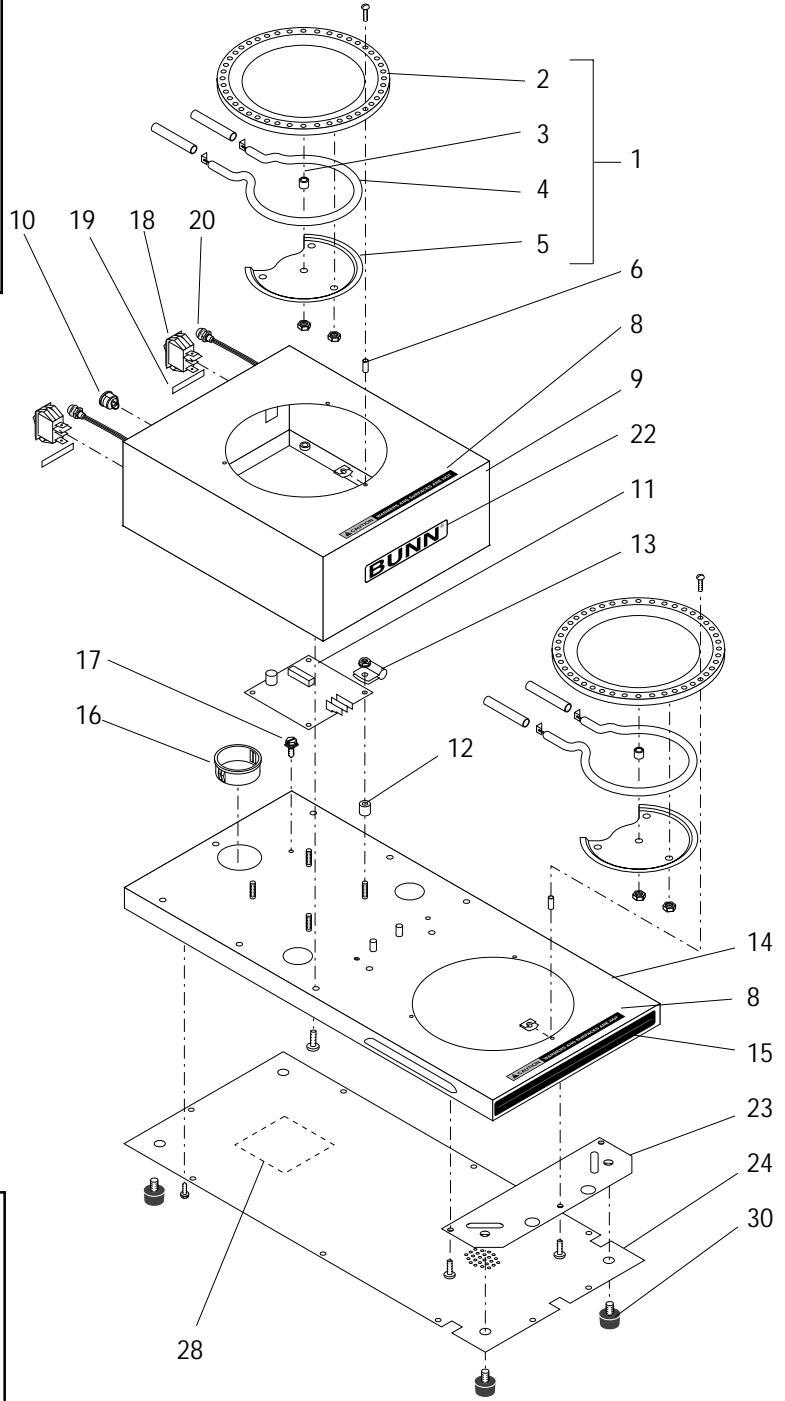
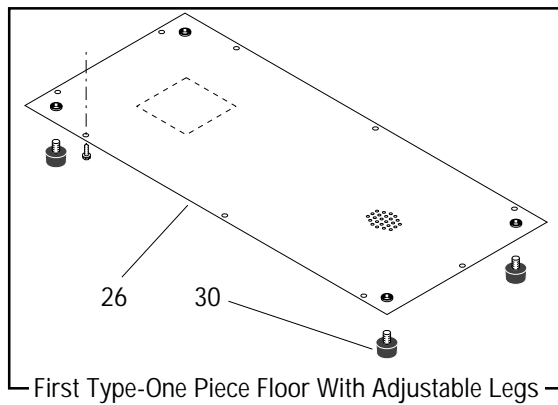
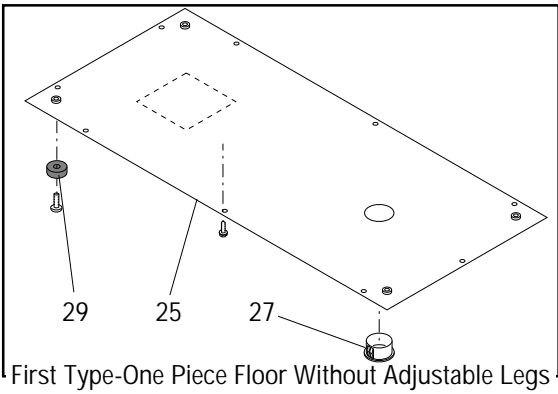
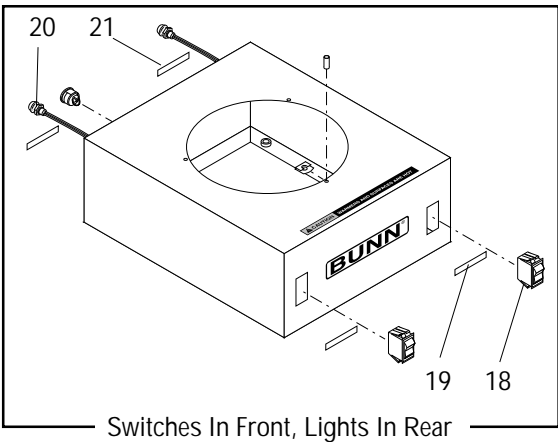
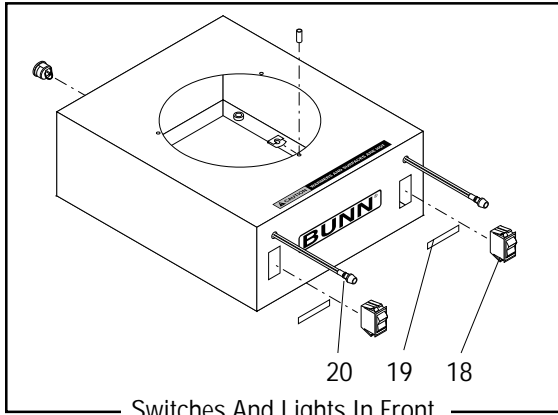

WARMER ASSEMBLY (with Fresh Light)

ITEM	PART NO.	QTY.	DESCRIPTION
1	11440.0006	2	Warmer Assy 100W, 120V (Includes items 2 thru 5)
	01304.0000	6	Screw, Pan Head #4-40 x .75"
	00916.0000	6	Fastener, J-Type #4-430
2	03656.0000	1	Warmer Dish
3	13042.0001	1	Spacer
4	11443.0000	1	Warmer Element 100W, 120V
5	05212.0000	1	Plate, Retaining
	00970.0000	2	Nut, Keps #8-32
6	03666.0000	6	Spacer, Warmer Dish
7	-----	4	Tube, Silicone, .25" Dia x 1.88" (Order item 35)
8	12364.0000	2	Decal, CAUTION - WARMERS ARE HOT
9	-----	1	Housing, Warmer (Not serviced separately)
	02308.0000	7	Screw, Truss Head #8-32 x .38"
10	02423.0000	1	Bushing, Strain Relief
11	28763.1000	1	Control Board, Freshness Light (Requires Programming)
	00973.0000	4	Nut, Keps #6-32
12	01533.0002	4	Spacer
13	26263.0002	1	Clamp
14	-----	1	Base, Warmer (Not serviced separately)
15	22306.0000	1	Decal, Red Stripe
16	01593.0000	1	Bushing, Hole 1.50" Dia.
17	02337.0001	1	Screw, Ground #10 x .375"
18	11444.0000	2	Switch, Lighted
19	28785.0000	1	Decal, LOWER
	28786.0000	1	Decal, FRONT
20	12517.0001	2	LED, Freshness Light
21	28785.0001	1] Lights in back, switches in front
	28786.0001	1	
22	00651.0000	1	Decal, BUNN

(Continued)

(Continued)

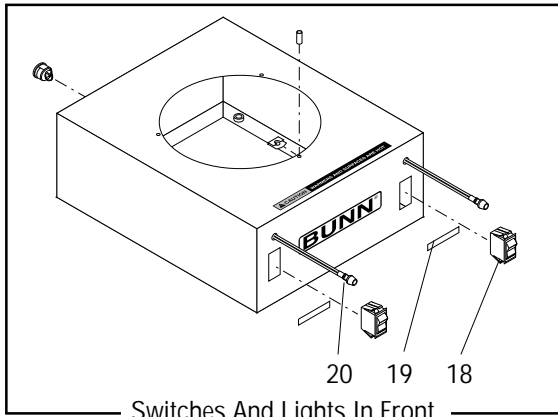

Switches And Lights In Front

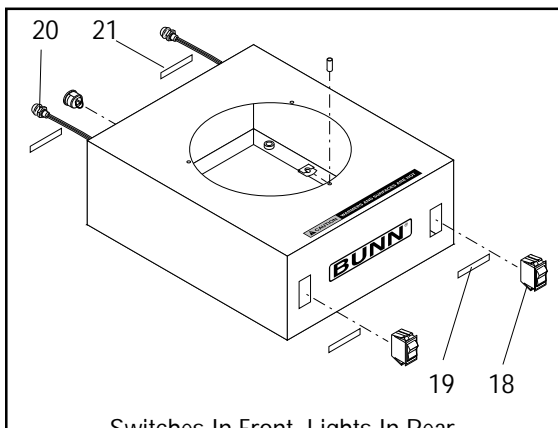

Switches In Front, Lights In Rear

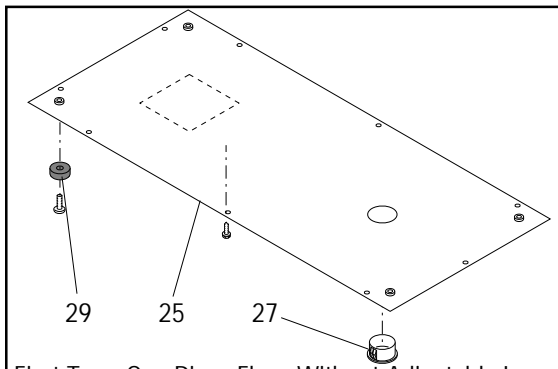

First Type-One Piece Floor Without Adjustable Legs

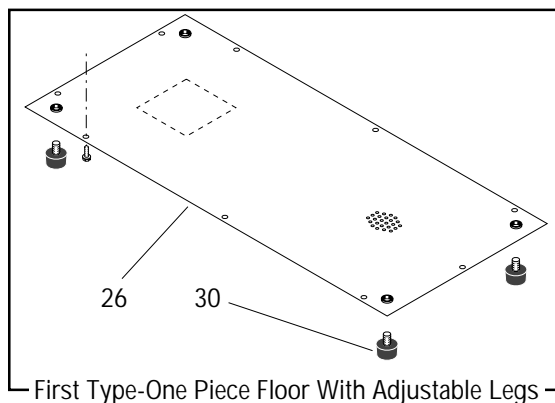

First Type-One Piece Floor With Adjustable Legs

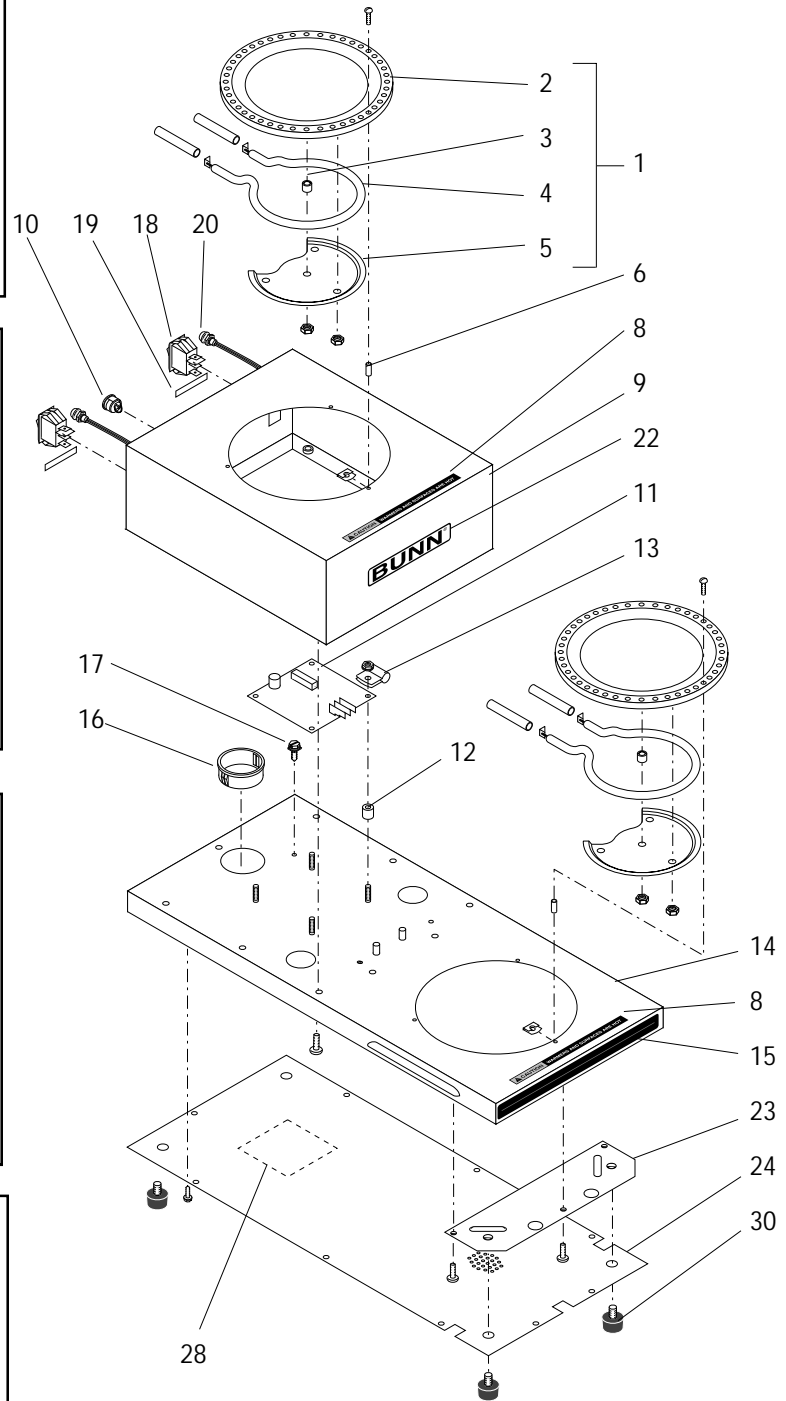

WARMER ASSEMBLY (with Fresh Light)

ITEM	PART NO.	QTY.	DESCRIPTION
23	29244.0000	1	Plate, Foot Mounting (Second Type with two piece floor)
	01347.0000	3	Screw, Truss Head #6-32 x .38"
24	29212.0000	1	Plate, Bottom Base (Second Type with two piece floor)
	02332.0002	9	Screw, Hex Crimptite #6 x .38"
25	-----	1	Plate, Bottom Base (One piece floor without adjustable legs. Order 29260.0000 and four 25137.0000)
	02332.0002	9	Screw, Hex Crimptite #6 x .38"
26	29260.0000	1	Plate, Bottom Base (First Type. One piece floor with adjustable legs)
	02332.0002	9	Screw, Hex Crimptite #6 x .38"
27	03011.0000	1	Plug, Vent 1.0" Dia (First Type. One piece floor without adjustable legs)
28	00986.0000	1	Decal, WARNING-ELECTRICAL
29	11435.0000	4	Foot, Rubber (One piece floor without adjustable legs)
	02308.0000	4	Screw, Truss Head #8-32 x .38"
			} Order item 34
30	25137.0000	4	Foot, Adjustable
Items 31 thru 35 are not illustrated			
31	28783.0000	1	Harness, Main
32	02405.0000	1	Power Cord
33	-----	2	Splice, Closed End (Not serviced)
34	22568.0000	1	Foot Kit (Includes 4 Feet and screws)
35	04828.1001	-	Tube, Silicone .25" Dia x 24.0"

NUMERICAL INDEX

PART NO.	PAGE NO.	PART NO.	PAGE NO.	PART NO.	PAGE NO.	PART NO.	PAGE NO.
00651.0000	9	28783.0000	11				
00786.0000	5	28785.0000	9				
00787.0000	5	28785.0001	9				
00824.0000	5	28786.0000	9				
00851.0000	5	28786.0001	9				
00916.0000	5,9	29212.0000	7,11				
00937.0000	5	29244.0000	7,11				
00970.0000	5,9	29260.0000	7,11				
00973.0000	9						
00986.0000	7,11						
01304.0000	5,9						
01347.0000	7,11						
01362.0000	5						
01375.0000	5						
01509.0000	5						
01512.0000	5						
01533.0002	9						
01593.0000	5,9						
01908.0000	5						
01951.0000	5						
02308.0000	5,7,9,11						
02332.0002	7,11						
02337.0001	5,9						
02405.0000	7,11						
02423.0000	5,9						
02817.0001	5						
02817.0002	5						
03011.0000	7,11						
03656.0000	5,9						
03666.0000	5,9						
04828.1001	7,11						
05212.0000	5,9						
11409.0000	5						
11421.0000	7						
11435.0000	7,11						
11440.0006	5,9						
11443.0000	5,9						
11444.0000	5,9						
11449.0000	7						
12364.0000	5,9						
12517.0001	9						
13042.0001	5,9						
21016.0011	5						
21016.0013	7						
21016.0024	5						
22306.0000	9						
22568.0000	7,11						
25137.0000	7,11						
26263.0002	9						
28763.1000	9						