



Service Manual – WB5N Hot Water Dispenser



Models Included

- WB5N
- WB5NL
- WB5N30
- WB5NB
- WB5NLB



CAUTION:

Equipment must be installed to comply with applicable federal, state, and local plumbing/electrical codes.



CAUTION:

Follow this setup procedure before attempting to use this unit. Failure to follow these instructions can result in injury and/or void of warranty.



CAUTION:

DO NOT connect the unit to hot water supply. The inlet valve is not rated for hot water.

ISO 9001:2008 REGISTERED

WILBUR CURTIS CO.
 6913 Acco Street,
 Montebello, CA 90640-5403
 For the latest information go to
www.wilburcurtis.com
 Tel: 800/421-6150
 Fax: 323/837-2410

Important Safeguards/Symbols

This equipment is designed for commercial use. Any servicing other than cleaning and routine maintenance should be performed by an authorized Wilbur Curtis Company service technician.

- DO NOT immerse the unit in water or any other liquid
- To reduce the risk of fire or electric shock, DO NOT open service panels. There are no user serviceable parts inside.
- Keep hands and other items away from hot areas of the unit during operation.
- Never clean with scouring powders or harsh chemicals.

Symbols:



WARNINGS – To help avoid personal injury



Important Notes/Cautions – from the factory



Sanitation Requirements

INSTALLATION

This Curtis unit is pre-set and ready to go from the factory.

System Requirements:

- Water Supply 20 – 90 PSI (MINIMUM FLOW RATE of 2 GPM)*
- Electrical: See electrical schematic.

SETUP STEPS

1. The unit should be level (left to right - front to back), on a secure surface.
2. Connect the water line to the water inlet fitting on the rear of the unit. Water volume going to the machine should be consistent. Use tubing sized sufficiently to provide a minimum flow rate of two gallons per minute.

NOTE: A water filtration system must be used to help maintain trouble-free operation. **Air must be purged from the cartridge prior to connection to equipment.** In areas with extremely hard water, we highly recommend the use of a Curtis approved water filter. For our full line of filters, please log on to www.wilburcurtis.com.



NSF requires the following water connection:

1. A quick disconnect or additional coiled tubing (at least 2x the depth of the unit) is required so that the unit can be moved for cleaning.
2. This unit must be installed with adequate backflow protection to comply with applicable federal, state and local codes.
3. Water pipe connections and fixtures directly connected to a portable water supply shall be sized, installed and maintained in accordance with federal, state, and local codes.

3. Connect the unit to electrical outlet with appropriate amperage rating (See serial tag on machine).
4. Once power has been supplied to the unit, flip the toggle switch to the 'ON' position (located on the rear of the unit), the water tank will begin to fill. When the water level in the tank reaches the probe, the heating element will turn on.
5. During the initial setup, the heating tank will reach operating temperature in 60 to 70 minutes (factory default 204°F).

* Expect flow rate from hot water faucet to be 1 GPM from WB5N and 2 GPM from WB5NL

For the latest specifications and information go to www.wilburcurtis.com

PROGRAMMING

UNIVERSAL CONTROL MODULE (UCM)

A FUNCTION

1. Press TEMP button for 1 second to check the set point temperature.
2. Press TEMP button for 3 seconds to enter heating tank temperature programming mode. The temperature in the heating tank is adjustable from 140° to 210° F.

To change temperature setting:

- a. Press ◀ to decrease temperature.
- b. Press ⏻ to set and exit programming.
- c. Press ▶ to increase at 2° increments.

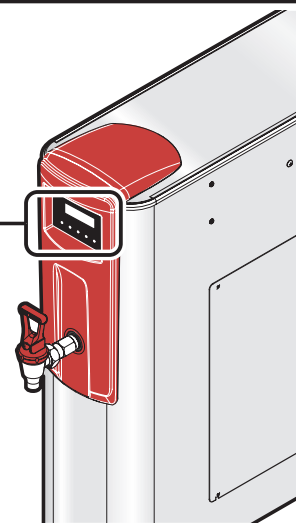
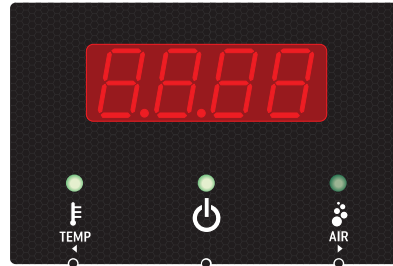

B FUNCTION

1. Press the AERATION button to pump air through the water in the heating tank.
2. Aerator pump will run as long as you hold down the button. Release button to stop.

I/O FUNCTION

1. ON/OFF button. Press once to activate control panel.
2. ON/OFF button used to set and exit programming.

LED SCREEN DISPLAY

When the unit is on and not in programming mode, the UCM will stay on and the LED screen will display the current tank temperature. The factory setting is 204°F. In the UCM programming, there is an option to change the screen display to read HOT instead of the set point temperature. You may also change the temperature units from Fahrenheit to Celsius.

To Change the LED To Read HOT:

1. Press the left TEMP button and hold down for 5 seconds. The F will start flashing.
2. Continue holding the TEMP button, at the same time, press and hold the ON/OFF button for 5 seconds.
3. Release both buttons. The program is now changed and the LED screen will display HOT.
4. While in the HOT display, pressing the TEMP button for 1 second will display the tank temperature.

To Change the LED To Read In Celsius:

NOTE: When the LED screen is in the HOT display mode, you cannot switch between Fahrenheit and Celsius. The LED screen must be in the Temperature display mode.

1. Press and hold down the TEMP button for 10 seconds. The temperature reading will change to Celsius.
2. Release the TEMP button. The LED screen will display the temperature in degrees Celsius (default is 96°C).

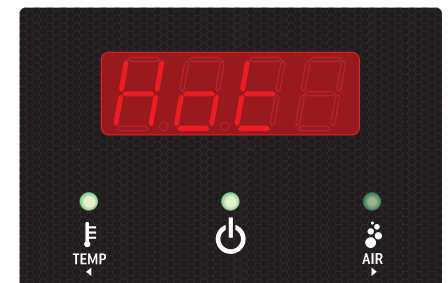
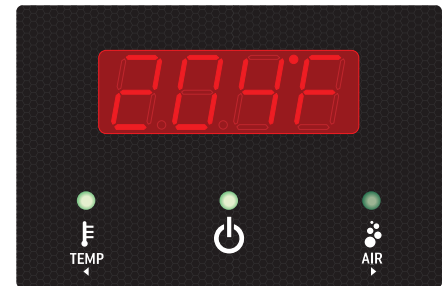

AERATOR

The aerator pump will automatically come on every 30 minutes. Aeration is factory set to run for 5 seconds. When the aeration is running, the display shows the LED bars chasing from left to right.

ERROR CODES

ERR1 = Overflow. Water level error.

ERR2 = Open sensor. Break in temperature thermistor circuit.

ENERGY SAVER

The Energy Saver Mode is Defaulted to off. To turn on the energy saver mode, press and hold both the ON and TEMP button for 10 seconds. Use the scroll buttons TEMP ◀ and ▶ AIR to choose OFF, ON, or 140°F. Press the ⏻ button to select.

If "OFF" is selected, Energy saver is disabled.

If "On" is selected, 4 Hr. after last dispense, the temp will not be maintained at any temperature (it will eventually drop to room temp).

If "140F" is selected, 4 Hr. after last dispense it maintains Tank Temp at 140F.

When the Energy Saver Mode is on, you can turn it off by pressing one of the control buttons or by simply dispensing some water through the faucet.

ILLUSTRATED PARTS LIST

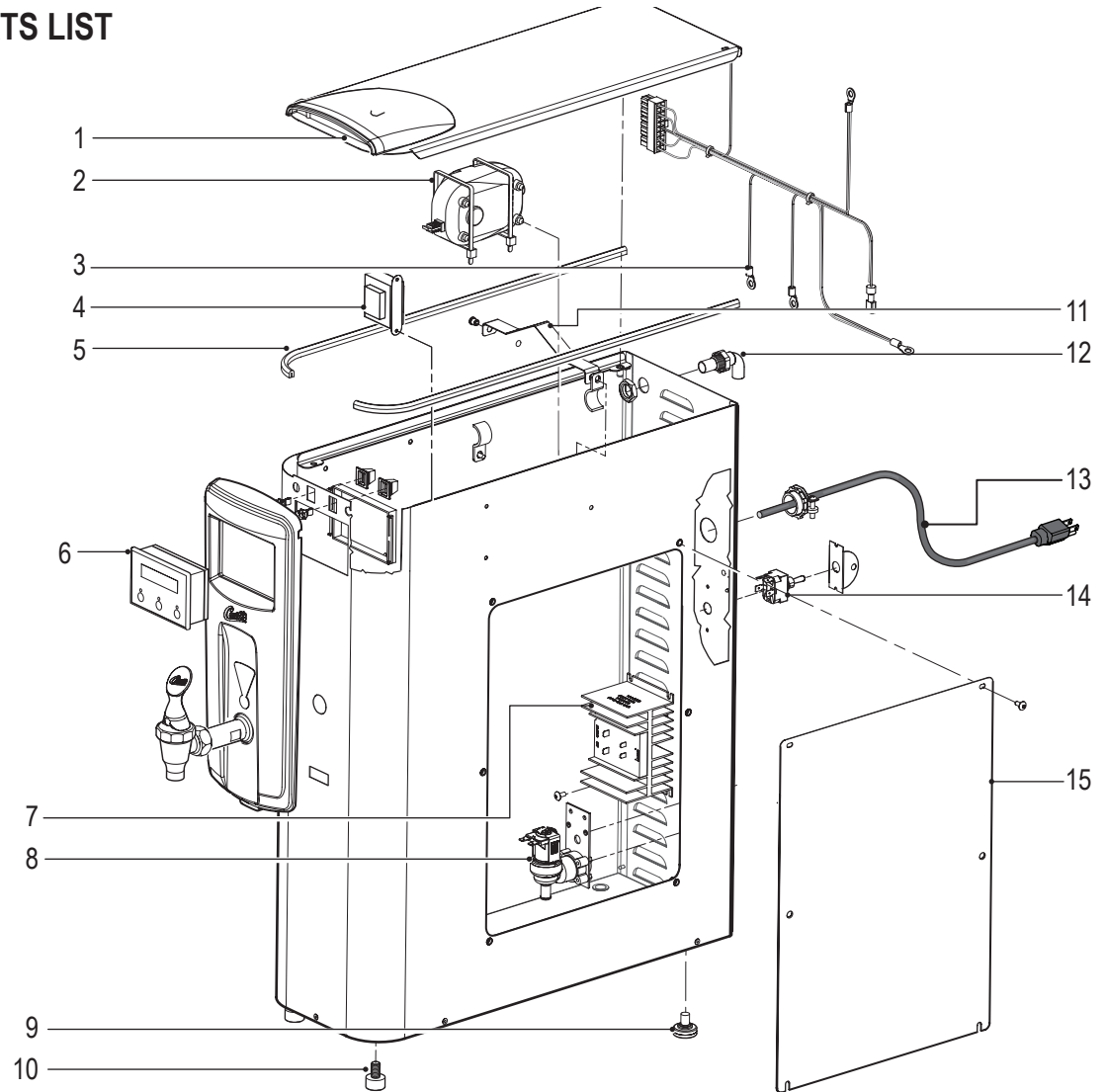

ITEM No	PART No	DESCRIPTION
1	WC-37567K	KIT, TOP COVER WB5N & WB5NL
1A	WC-37579BLK	KIT, TOP COVER WB5NB & WB5NLB BLACK
2	WC-1048-101*	PUMP ASSEMBLY, AGITATION (120V)
2A	WC-1009-101	PUMP, AGITATION 220V W/CAPACITOR & TERMINALS
3	WC-13046-101	HARNESS ASSEMBLY, DV WB5N & WB5NL
4	WC-718 *	TRANSFORMER, 120VAC-12VAC 500mA W/PIGTAIL WIRES
4A	WC-719	TRANSFORMER, 240/120VAC-12VAC
5	WC-53157-101	TRIM, EDGE GUARD CHROME
6	WC-794K *	KIT, MINI UNIVERSAL CONTROL MODULE 120VAC W/LABEL
7	WC-8559*	RELAY, SOLIDSTATE 40A W/INTEGRATED HEATSINK
8	WC-847*	VALVE, INLET 2 GPM 120V 10W
8A	WC-883	VALVE, INLET 2 GPM 240V 10W
9	WC-3518*	LEG, GLIDE 3/8"-16 STUD SCREW
10	WC-3503*	LEG, 3/8"-16 STUD SCREW BUMPER
11	WC-61987	BRACKET, STIFFENER
12	WC-2948	FITTING, TANK OVERFLOW
13	WC-1200	CORD, 14/3 SJTO 6' BLK W/PLUG
14	WC-103 *	SWITCH, TOGGLE DPST 25A 125/250VAC RESISTIVE

* SUGGESTED PARTS TO STOCK

ILLUSTRATED PARTS LIST

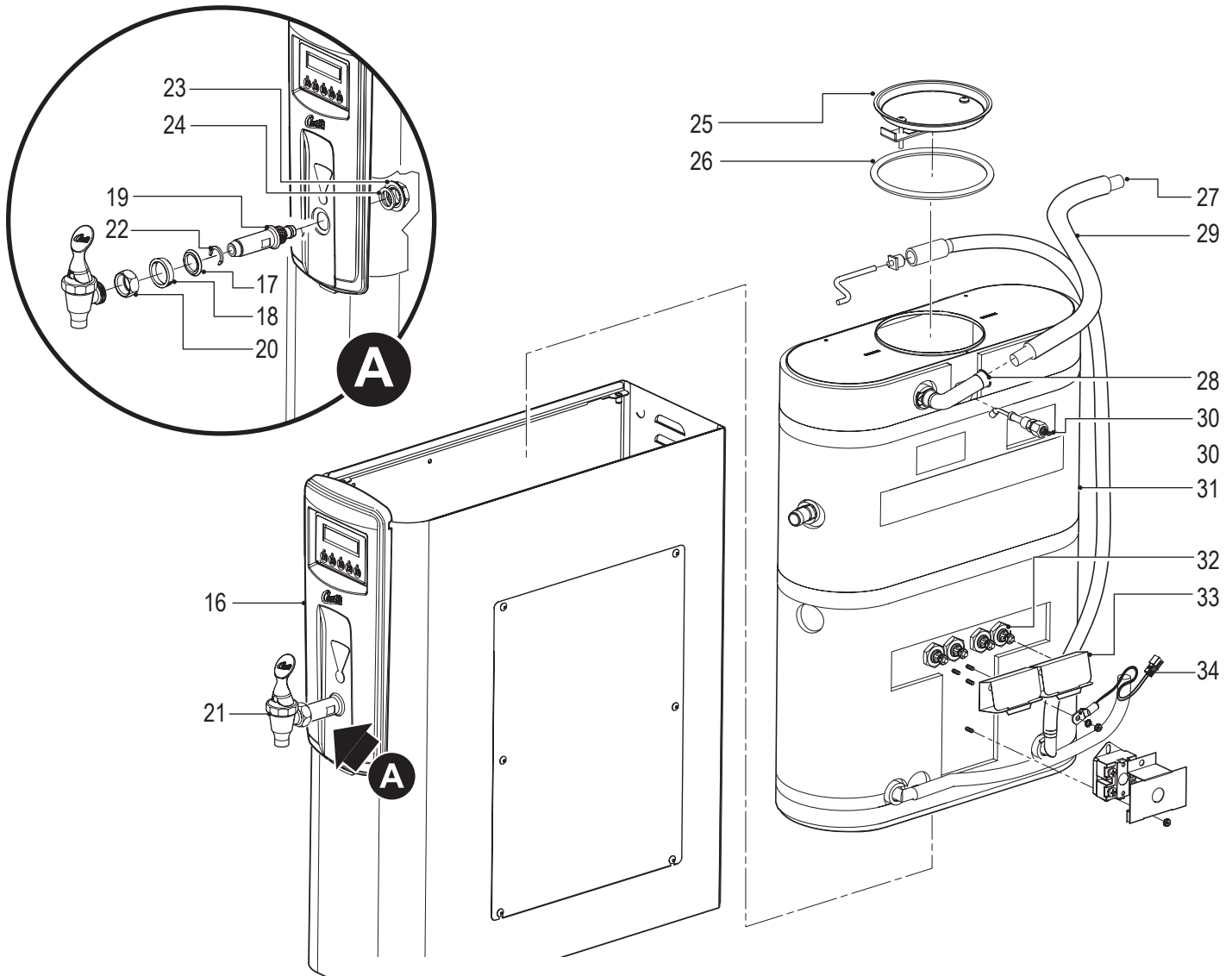

ITEM No	PART No	DESCRIPTION
15	WC-61549-101	COVER, SIDE ACCESS
15A	WC-61549-101BLK	COVER, SIDE ACCESS BLACK WB5N/NL/5NB/5NLB
16	WC-37568K	KIT, FRONT COVER WB5N & WB5NL
16A	WC-37578BLK	KIT, FRONT COVER WB5NB & WB5NLB (BLACK)
17	WC-43157	GROMMET, RUBBER 0.89" ID
18	WC-43158	BUSHING, PLASTIC 1.375 OD
19	WC-1955	SHANK, FAUCET PLAIN
20	WC-1903	NUT, UNION SHANK
21	WC-1800HW*	FAUCET, S' SERIES HOT WATER
22	WC-1906	C'RING, .917 x .760 x .090
23	WC-1939	NUT, FLANGED
24	WC-1813	WASHER, 1 1/8" O.D.
25	WC-37008*	KIT, TANK LID ROUND
26	WC-43067*	O'RING, 4 1/2 I.D. x Ø.285 C.S. SILICONE
27	WC-5310	TUBE, 5/16 I.D. x 1/8" W SILICONE (4.25 FT)
28	WC-2471	ELBOW, SILICONE

* SUGGESTED PARTS TO STOCK

ILLUSTRATED PARTS LIST

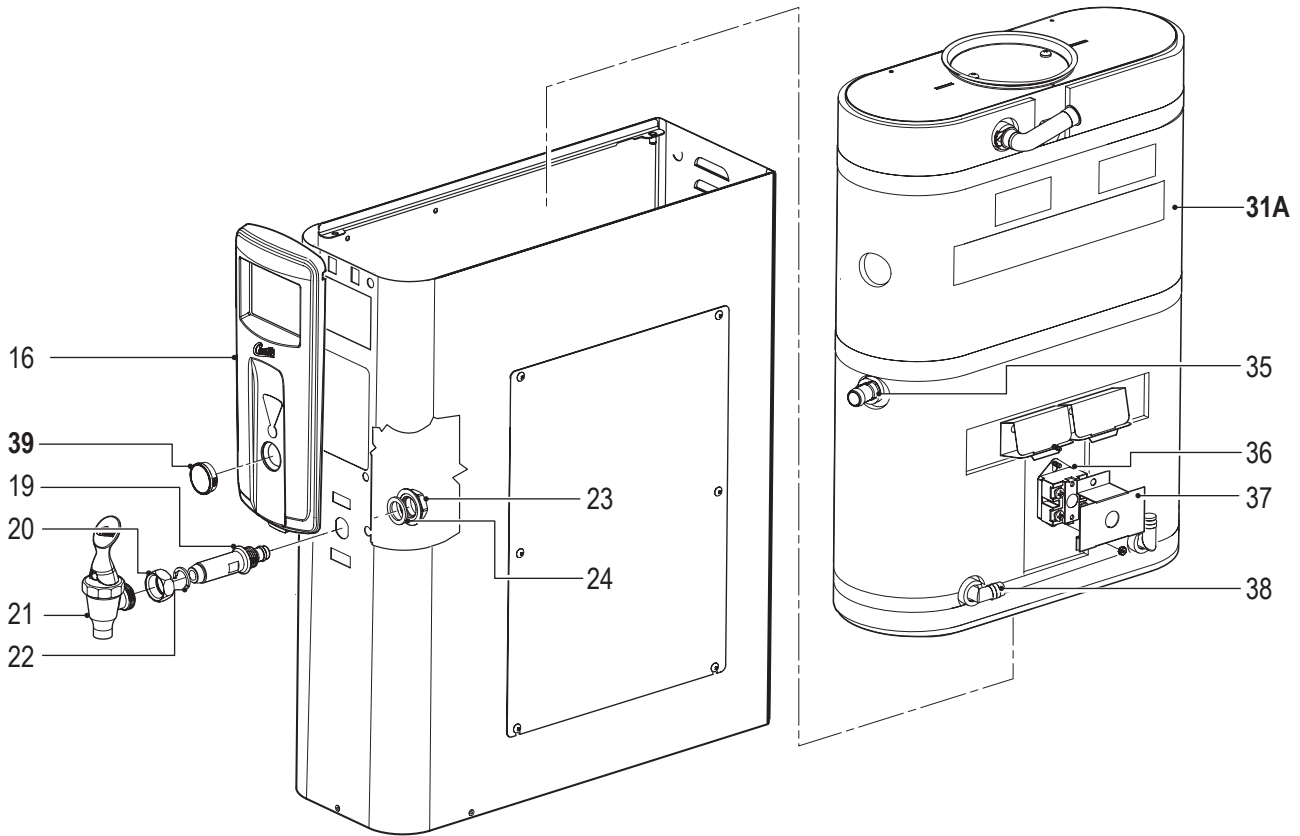

NOTE: The WB5NL unit is illustrated on this page. Many of the parts shared between the three hot water dispensers. Parts unique to the WB5NL are noted in bold type.

ITEM №	PART №	DESCRIPTION
29	WC-5350	TUBE, Ø1/2" x 1/8" WALL SILICONE (1.5 FT)
30	WC-5502-01*	PROBE, WATER LEVEL
31	WC-54339	TANK ASSEMBLY, WB5N
31A	WC-54339-101	TANK ASSEMBLY, WB5NL
32	WC-934-04 *	HEATING ELEMENT, 220VAC 2500W
33	WC-4394	GUARD, SHOCK HEATING ELEMENT
34	WC-1438-101*	SENSOR, TEMPERATURE TANK
35	WC-37357*	KIT, STRAIGHT PLASTIC FITTING AND BUSHING 12MM
36	WC-522 *	THERMOSTAT, HI LIMIT HEATER DPST 277V-40A
37	WC-43055	GUARD, SHOCK RESET THERMOSTAT
38	WC-37266*	KIT, FITTING TANK OVERFLOW
39	WC-43159	PLUG, HOLE 1.375"

* SUGGESTED PARTS TO STOCK

ELECTRICAL SCHEMATIC

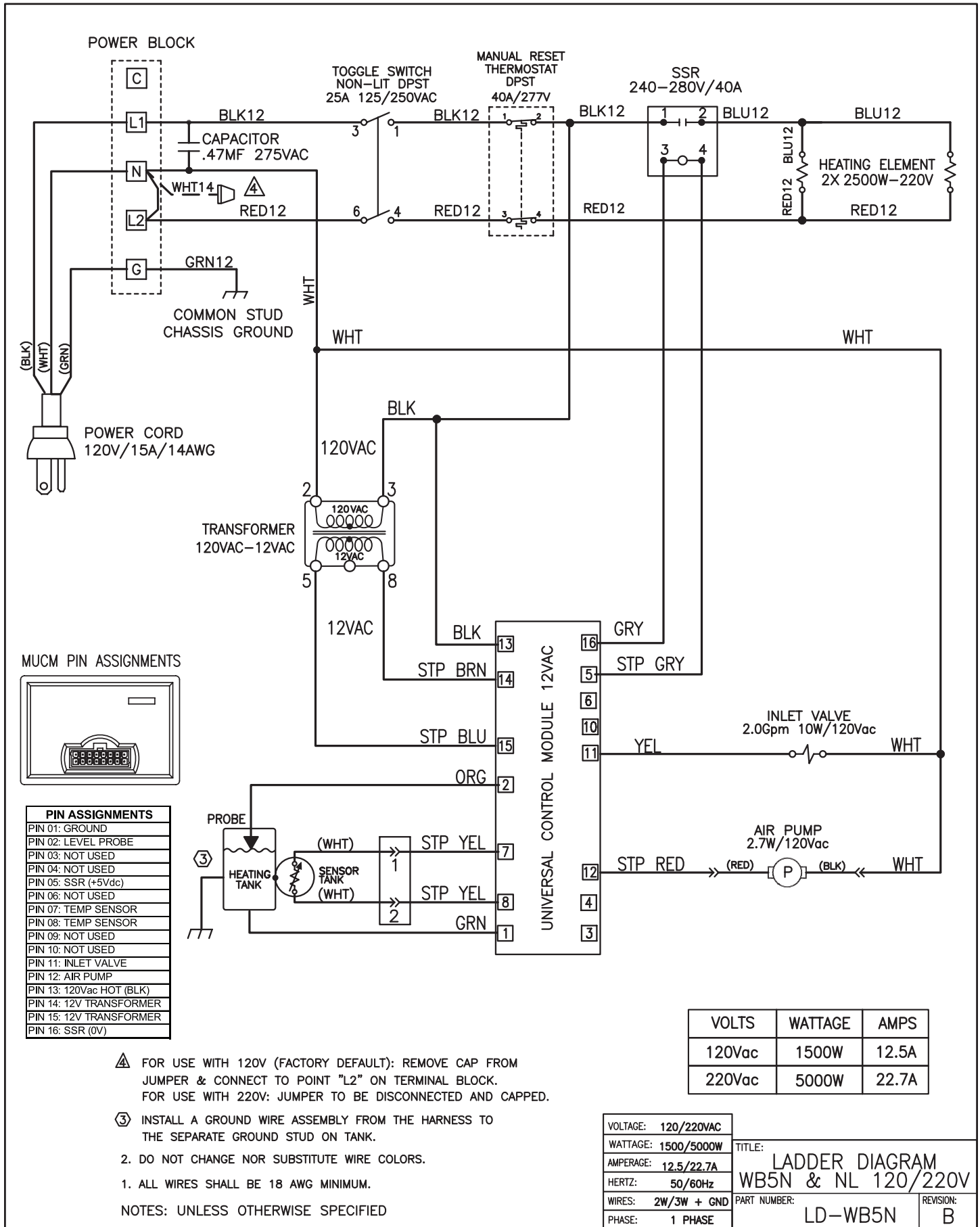

ELECTRICAL SCHEMATIC

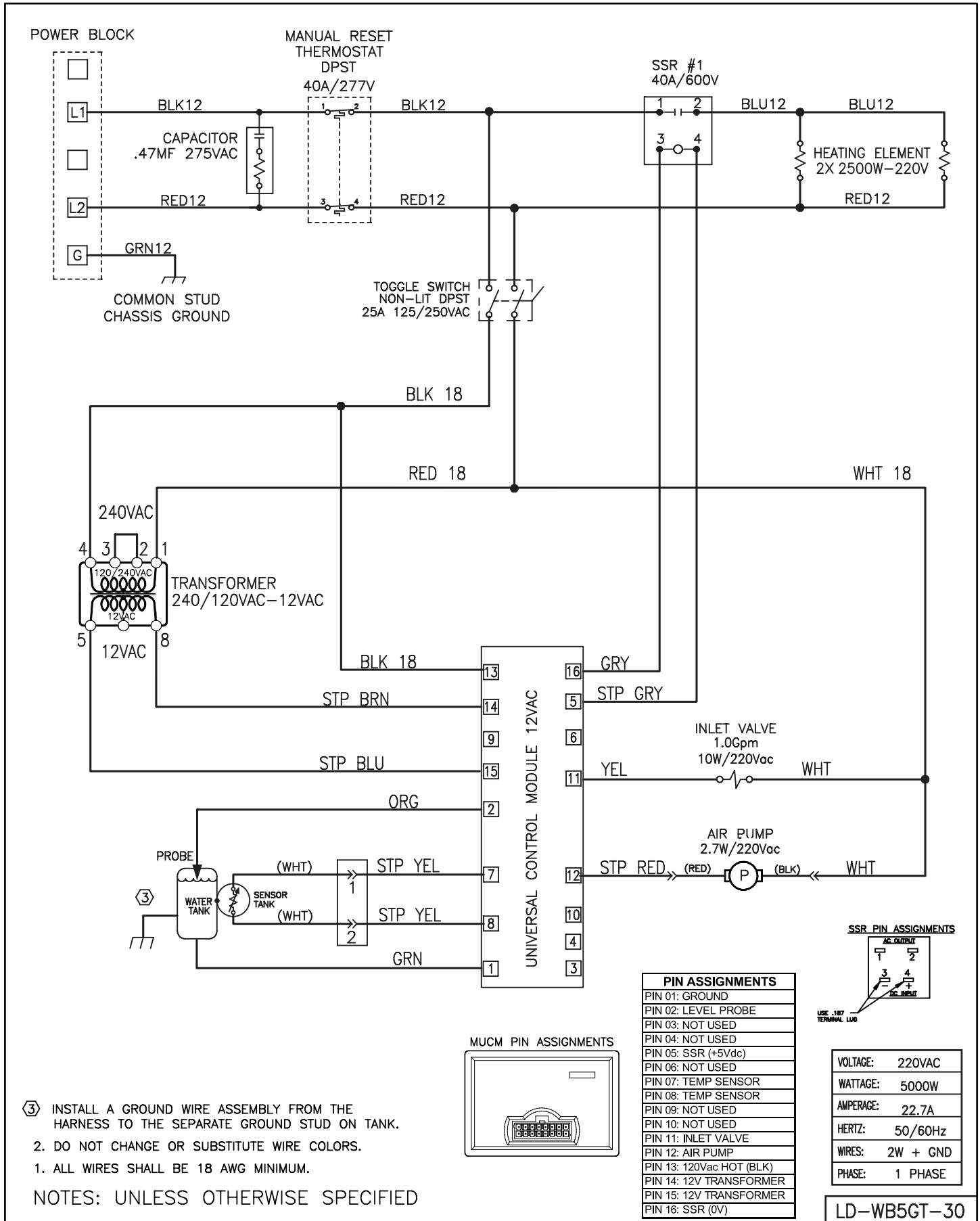

**WB5N
ROUGH-IN DRAWING**

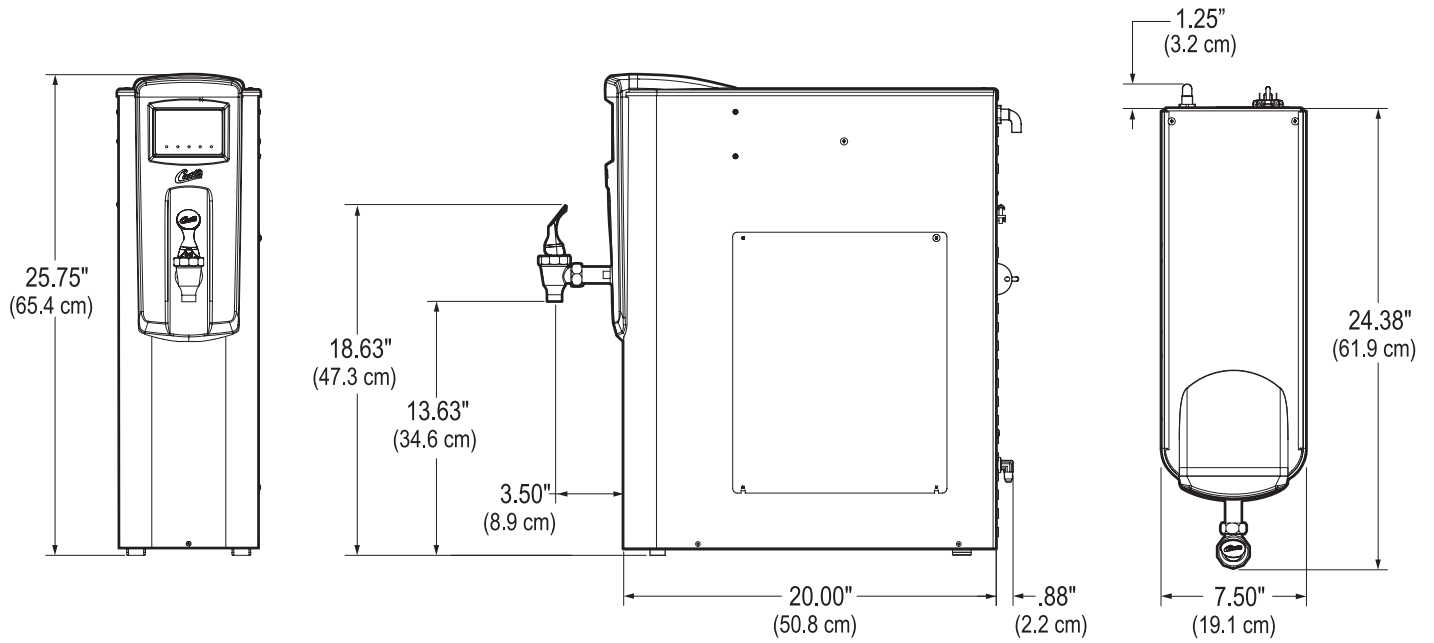

**WB5NL
ROUGH-IN DRAWING**

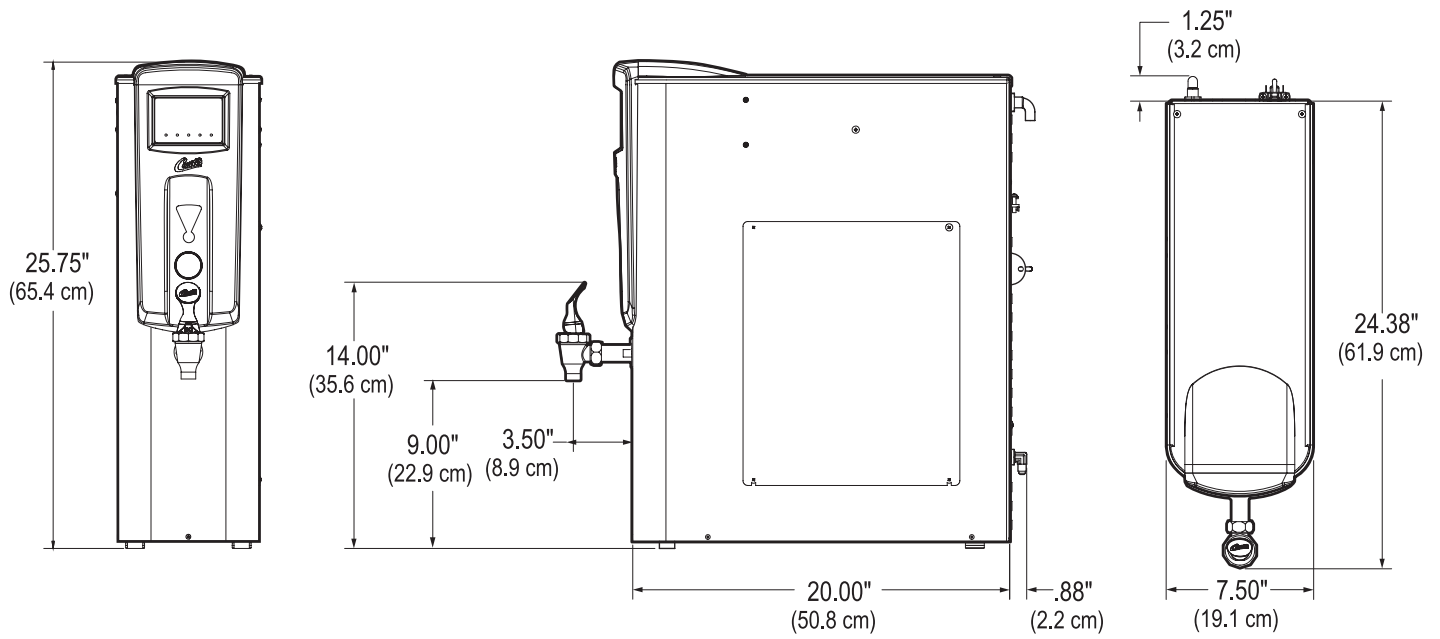

CLEANING

Regular cleaning and preventive maintenance is essential in keeping your hot water dispenser looking and working like new. To clean the hot water dispensing unit and components, prepare a mild solution of detergent and warm water.



CAUTION – Do not use cleansers, bleach liquids, powders or any other substance containing chlorine. These products promote corrosion and will pit the stainless steel. **USE OF THESE PRODUCTS WILL VOID THE WARRANTY.**

DAILY CLEANING

1. Wipe exterior surfaces with a cloth soaked with a mild detergent solution. Wipe off any water spots, food spills, or crumbs.
2. Rinse off the area using a cloth soaked in clean water to remove any residual cleaning solution.
3. Dry the area.
4. If a drip tray is used, dump out the water and clean inside the tray. Remove the screen and wash.
5. Dry the tray.
6. On a stainless finish, rub stainless steel polish on the outside surfaces to protect the cabinet.

Product Warranty Information

The Wilbur Curtis Company certifies that its products are free from defects in material and workmanship under normal use. The following limited warranties and conditions apply:

3 Years, Parts and Labor, from Original Date of Purchase on digital control boards.

2 Years, Parts, from Original Date of Purchase on all other electrical components, fittings and tubing.

1 Year, Labor, from Original Date of Purchase on all electrical components, fittings and tubing.

Additionally, the Wilbur Curtis Company warrants its Grinding Burrs for Forty (40) months from date of purchase or 40,000 pounds of coffee, whichever comes first. Stainless Steel components are warranted for two (2) years from date of purchase against leaking or pitting and replacement parts are warranted for ninety (90) days from date of purchase or for the remainder of the limited warranty period of the equipment in which the component is installed.

All in-warranty service calls must have prior authorization. For Authorization, call the Technical Support Department at 1-800-995-0417. Effective date of this policy is April 1, 2003.

Additional conditions may apply. Go to www.wilburcurtis.com to view the full product warranty information.

CONDITIONS & EXCEPTIONS

The warranty covers original equipment at time of purchase only. The Wilbur Curtis Company, Inc., assumes no responsibility for substitute replacement parts installed on Curtis equipment that have not been purchased from the Wilbur Curtis Company, Inc. The Wilbur Curtis Company will not accept any responsibility if the following conditions are not met. The warranty does not cover and is void under the following circumstances:

- 1) Improper operation of equipment: The equipment must be used for its designed and intended purpose and function.
- 2) Improper installation of equipment: This equipment must be installed by a professional technician and must comply with all local electrical, mechanical and plumbing codes.
- 3) Improper voltage: Equipment must be installed at the voltage stated on the serial plate supplied with this equipment.
- 4) Improper water supply: This includes, but is not limited to, excessive or low water pressure, and inadequate or fluctuating water flow rate.
- 5) Adjustments and cleaning: The resetting of safety thermostats and circuit breakers, programming and temperature adjustments are the responsibility of the equipment owner. The owner is responsible for proper cleaning and regular maintenance of this equipment.
- 6) Damaged in transit: Equipment damaged in transit is the responsibility of the freight company and a claim should be made with the carrier.
- 7) Abuse or neglect (including failure to periodically clean or remove lime accumulations): Manufacturer is not responsible for variation in equipment operation due to excessive lime or local water conditions. The equipment must be maintained according to the manufacturer's recommendations.
- 8) Replacement of items subject to normal use and wear: This shall include, but is not limited to, light bulbs, shear disks, "O" rings, gaskets, silicone tube, canister assemblies, whipper chambers and plates, mixing bowls, agitation assemblies and whipper propellers.
- 9) Repairs and/or Replacements are subject to our decision that the workmanship or parts were faulty and the defects showed up under normal use. All labor shall be performed during regular working hours. Overtime charges are the responsibility of the owner. Charges incurred by delays, waiting time, or operating restrictions that hinder the service technician's ability to perform service is the responsibility of the owner of the equipment. This includes institutional and correctional facilities. The Wilbur Curtis Company will allow up to 100 miles, round trip, per in-warranty service call.

RETURN MERCHANDISE AUTHORIZATION: All claims under this warranty must be submitted to the Wilbur Curtis Company Technical Support Department prior to performing any repair work or return of this equipment to the factory. All returned equipment must be repackaged properly in the original carton. No units will be accepted if they are damaged in transit due to improper packaging. **NO UNITS OR PARTS WILL BE ACCEPTED WITHOUT A RETURN MERCHANDISE AUTHORIZATION (RMA). RMA NUMBER MUST BE MARKED ON THE CARTON OR SHIPPING LABEL.** All in-warranty service calls must be performed by an authorized service agent. Call the Wilbur Curtis Technical Support Department to find an agent near you.

ECN 15491 . 6/10/14@13.2 . revD



WILBUR CURTIS CO., INC.

6913 Acco St., Montebello, CA 90640-5403 USA

Phone: 800/421-6150 ♦ Fax: 323-837-2410

♦ Technical Support Phone: 800/995-0417 (M-F 5:30A - 4:00P PST) ♦ E-Mail: techsupport@wilburcurtis.com

♦ Web Site: www.wilburcurtis.com

For The Latest Specification Information Go To www.wilburcurtis.com